



Delaware Sand Filters

Design Guidance

December 2020

**California Department of Transportation
HQ Division of Design**

For individuals with sensory disabilities, this document is available in alternate formats upon request. Please call or write to:

**Caltrans Division of Design
Office of Hydraulics and Stormwater Design
P.O. Box 942874, Sacramento, CA 94274-0001**

(916) 653-8896 Voice or dial 711 to use a relay service.

Table of Contents

List of Figures.....	v
List of Tables	v
List of Abbreviations.....	vii
1. Introduction	1-1
1.1 Design Responsibility.....	1-1
1.2 Delaware Sand Filters	1-2
1.2.1 Types of Delaware Sand Filters.....	1-2
2. Basis of BMP Detail Drawings.....	2-1
2.1 Design Basis	2-1
2.2 Design Criteria.....	2-2
2.3 Special Designs	2-3
2.4 Inline vs. Offline Placement.....	2-3
2.5 Safety Considerations.....	2-3
2.6 Restrictions/Coordination.....	2-4
3. Getting Started	3-1
3.1 Preliminary Design Parameters	3-1
3.1.1 Contributing Drainage Area and WQV.....	3-2
3.2 Preliminary Calculations.....	3-2
3.2.1 DSF Design Procedures	3-2
3.2.2 DSF Dimensions	3-3
3.2.3 DSF Wall Heights	3-7
3.2.4 Inlet and Outlet Structure	3-7
3.2.4.1 Pipe Inlet and Pipe Outlet	3-7
3.2.4.2 Curb Inlet	3-8
3.2.5 Overflow Structure and Headwater Depth	3-8
3.2.5.1 Overflow Weir.....	3-8
3.2.5.2 Overflow Pipe	3-9
3.2.6 Sedimentation Chamber Baffle Wall.....	3-9
4. BMP Selection.....	4-1
4.1 Review Site Conditions	4-1
4.2 Select DSD Type and Configuration	4-1
4.3 Determine DSF Wall Heights and Total Depth	4-4
4.4 Check DSF Footprint	4-5
5. BMP Layout.....	5-1
5.1 DSF Layout.....	5-1

TABLE OF CONTENTS

5.2	Space Considerations.....	5-1
5.3	Construction Requirements and Restrictions	5-1
5.4	Inlet and Outlet Pipe Diameter	5-2
5.5	Hydraulic Head.....	5-2
6.	Design Elements.....	6-1
6.1	Maintenance	6-1
6.2	Design Storm	6-1
6.3	Overflow Events	6-1
6.4	Overflow Devices	6-2
6.5	Flow Splitters.....	6-2
6.6	Excessive Flows	6-2
6.7	Upstream Effects.....	6-3
6.8	Potential Downstream Impacts.....	6-3
6.9	Underdrain System	6-3
6.10	Litter and Trash Considerations	6-4
7.	PS&E Preparation	7-1
7.1	PS&E Drawings	7-1
7.2	Specifications.....	7-2
7.2.1	Standard Specifications	7-2
7.2.2	Standard Special Provisions	7-3
7.2.3	Non-Standard Special Provisions	7-3
7.3	Project Cost Estimates.....	7-4
7.3.1	PID and PA/ED Phases.....	7-4
7.3.2	PS&E Phase	7-5
7.4	Developing DSF Cost Estimates	7-5
7.5	Plan Sheet Approval	7-6
8.	Special Design	8-1
8.1	Alternative Filter Media	8-1
8.2	Alternative BMP Sizing	8-1
8.3	Oversized Inlet Pipe	8-3
8.4	Greater Wall Height.....	8-3
8.5	Site Limitations.....	8-3
8.6	Customizing the DSF Detail Drawings	8-4
9.	Design Example	9-1
9.1	DSF Selection Example.....	9-1
9.2	PS&E Preparation.....	9-4
9.3	Alternative Design Considerations	9-4
10.	References.....	10-1



List of Figures

Figure 1-1. DSF Subtype 1 Isometric View	1-3
Figure 1-2. DSF Subtype 2 Isometric View	1-4
Figure 1-3. DSF Subtype 3 Isometric View	1-4
Figure 3-1. DSF Dimensional Relationship (Subtype 2)	3-4
Figure 4-1: Typical DSF Selection Flow Chart	4-2
Figure 4-2. DSF Wall Height Determination	4-5
Figure 8-1. Example of Maximum WQV Treated in a Media Filter	8-2
Figure 9-1. DSF Location	9-5
Figure 9-2. DSF Layout.....	9-6
Figure 9-3. System Profile	9-7
Figure 9-4. DSF Wall and Footing Elevations	9-8

List of Tables

Table 1-1. DSF Subtypes and Selection Criteria.....	1-5
Table 2-1. DSF Design Criteria	2-2
Table 3-1. DSF Sizing Summary	3-5



TABLE OF CONTENTS

This page intentionally left blank.

List of Abbreviations

AASHTO	American Association of State Highway and Transportation Officials	SWDR	Stormwater Data Report
BEES	Basic Engineering Estimating System	SWRCB	State Water Resources Control Board
BMP	Best Management Practice	TBMP	Treatment Best Management Practice
CRZ	Clear Recovery Zone, (AASHTO Clear Zone)	WQF	Water Quality Flow
CF	cubic feet	WQV	Water Quality Volume
cfs	cubic feet per second		
DES	Division of Engineering Services		
DSF	Delaware Sand Filter		
DPPIA	Design Pollution Prevention Infiltration Area		
EPA	Environmental Protection Agency		
FHWA	Federal Highway Administration		
ft	foot/feet		
ft/s	foot/feet per second		
HDS	Hydraulic Design Series		
HDM	Highway Design Manual		
HEC	Hydraulic Engineering Circular		
HQ	Headquarters		
LID	low impact development		
NPDES	National Pollutant Discharge Elimination System		
nSSP	Non-Standard Special Provisions		
OHSD	Office of Hydraulics and Stormwater Design		
PA/ED	Project Approval/Environmental Document		
PDT	Project Development Team		
PE	Project Engineer		
PECE	Preliminary Engineer's Cost Estimate		
PID	Project Initiation Document		
PPCE	Project Planning Cost Estimate		
PPDG	Project Planning and Design Guide		
PS&E	Plans, Specifications and Estimates		
SQFT	square foot/feet		
SSHM	Small Storm Hydrology Method		
SSP	Standard Special Provision		



TABLE OF CONTENTS

This page intentionally left blank.



Section 1

Introduction

This document provides guidance to Caltrans Designers for incorporating the Delaware Sand Filter (DSF) as Treatment Best Management Practices (TBMPs) and Detail Drawings into projects during the planning and design phases. The DSF is a Caltrans-approved Stormwater TBMP and is one of the two devices identified in the Project Planning and Design Guide (PPDG) as Media Filters. The DSF may also be known as a Delaware Filter or Media Filter. The primary functions of this document are to:

1. Describe a DSF
2. Provide design guidance
3. Review the required elements for implementing a DSF into Plans, Specifications, and Estimates (PS&E) packages
4. Provide a design example

It is assumed that the need for post construction TBMPs has already been determined in accordance with the guidelines and procedures presented in the Project Planning and Design Guide (PPDG; Caltrans 2019b).

The following guidance is provided based on Caltrans pilot studies and professional design experience. Designers may utilize alternatives to the calculation methodologies presented in this guidance. Alternative calculations and design decisions must be documented in the project Stormwater Data Report (SWDR) and the Project File. The SWDR template can be found in the PPDG.

1.1 Design Responsibility

The Project Engineer (PE) is responsible for the design of DSF hydrology, hydraulics, grading, and traffic because they are part of the highway drainage system. The designer must consider the highway grading plans and the impacts stormwater infiltration may have on the roadway especially in consideration of the clear recovery zone (CRZ). Coordinate with other functional experts to implement successful and functioning DSFs.

Refer to Chapter 800 of the Highway Design Manual, the Headquarters (HQ) Office of Hydraulics and Stormwater Design (OHSD), and District Hydraulics for project drainage requirements. To achieve sustainability requirements, the Project Development Team (PDT) is encouraged to use native and climate appropriate vegetation that does not require irrigation and requires the least amount of maintenance.



1.2 Delaware Sand Filters

DSFs were originally developed in the State of Delaware by the Department of Natural Resources and Environmental Control. The DSF was determined by Caltrans during the BMP Retrofit Pilot Program (Caltrans 2004) to be effective, and therefore, was approved for statewide use in February 2005. DSFs can be used to treat stormwater runoff generated by the Water Quality Event by reducing the discharge of pollutants such as total suspended solids, particulate metals, dissolved metals, and litter.

The DSF consists of two parallel concrete chambers divided by a weir wall. The first chamber serves as a sedimentation chamber, and the second chamber serves as a filter chamber. The filtered effluent is captured by perforated underdrains located beneath the filter layer. A third chamber, placed at the downstream end of the structure and abutting both the sedimentation and filtration chambers, serves as both a WQV release and an overflow release chamber. All chambers of the DSF project above grade a minimum of 6 inches and are fitted with covers to seal the device.

Runoff enters the sedimentation chamber either through curb inlets or pipes, causing the sedimentation pool to rise and overflow into the filter chamber over the weir wall. The dividing weir wall provides a level surface for runoff to discharge onto the filter media as sheet flow to minimize scouring of the filter media and to distribute the runoff across the length of the filter chamber. The permanent pool in the sedimentation chamber stores heavier particle deposits. Floatable materials and hydrocarbon films, however, may reach the filter media from the sedimentation chamber. During the Design Storm events, stormwater levels rise and flow into the overflow chamber via an overflow weir or overflow pipes. A baffle wall prevents the floatables from entering the overflow chamber.

The DSF configurations and sizing calculations in this guidance are intended for standard inline designs under normal conditions with typical external loading requirements. It is preferred that DSFs be placed offline with an upstream flow splitter to minimize the size of the BMP. See Section 6.5 for additional details. Additionally, the calculations in this guidance assume instantaneous runoff to the BMP (i.e., 'slug-flow') which is likely conservative. Alternative sizing calculations, like unsteady-flow storage routing, may be used to refine the BMP size, see Section 8.2. Consult with Geotechnical Design, Hydraulics, and Traffic Safety if within the CRZ.

1.2.1 Types of Delaware Sand Filters

Three DSF subtypes were developed to satisfy various siting conditions, including two configurations that are considered vector proof which seal off the permanent pool between storm events. Coordinate designs with the local vector control district. These subtypes are designated based on the inlet and overflow mechanisms, and are shown in Figure 1-1 (Subtype 1), Figure 1-2 (Subtype 2), and

Figure 1-3 (Subtype 3). A description of DSF subtypes and their selection criteria are included in Table 1-1. Note that an upstream flow splitter is not shown in Figures 1-1 and 1-2 but should be installed upstream of the inlet pipe when feasible. Consult with Geotechnical Design, Hydraulics, and Traffic Safety if within the CRZ.

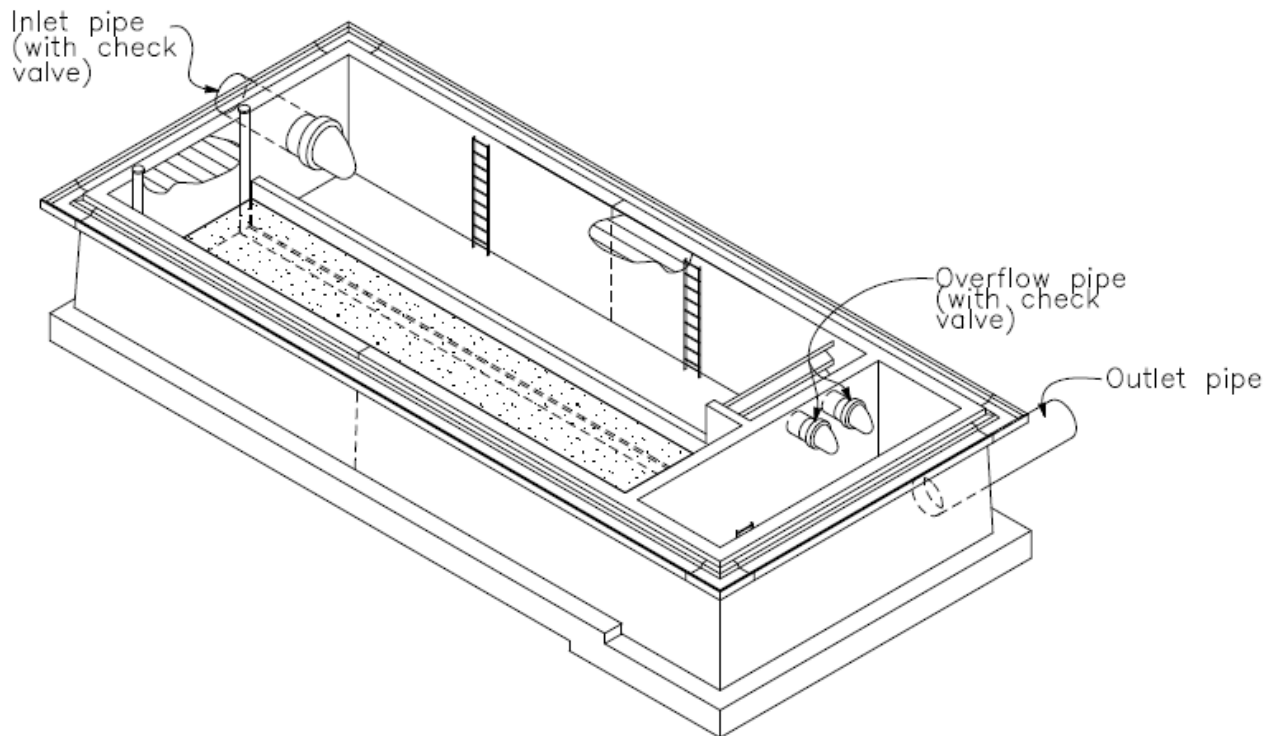

Figure 1-1. DSF Subtype 1 Isometric View

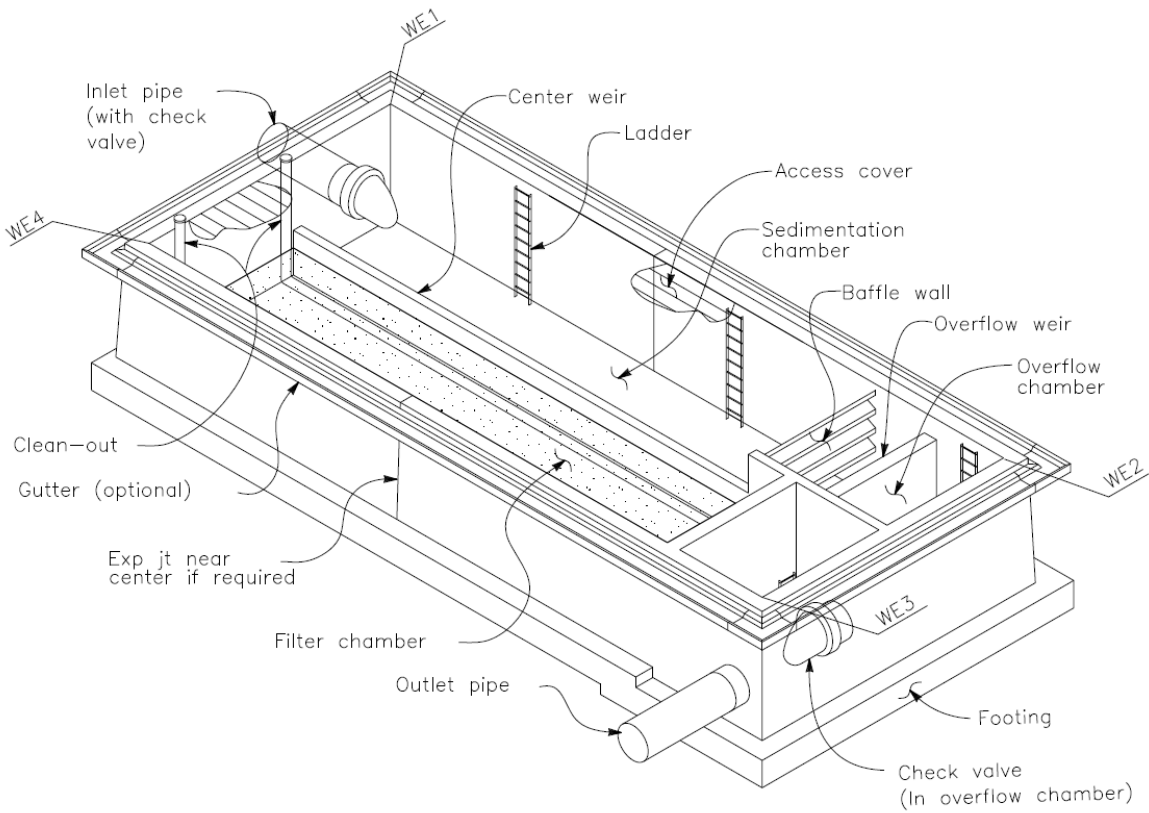

Figure 1-2. DSF Subtype 2 Isometric View

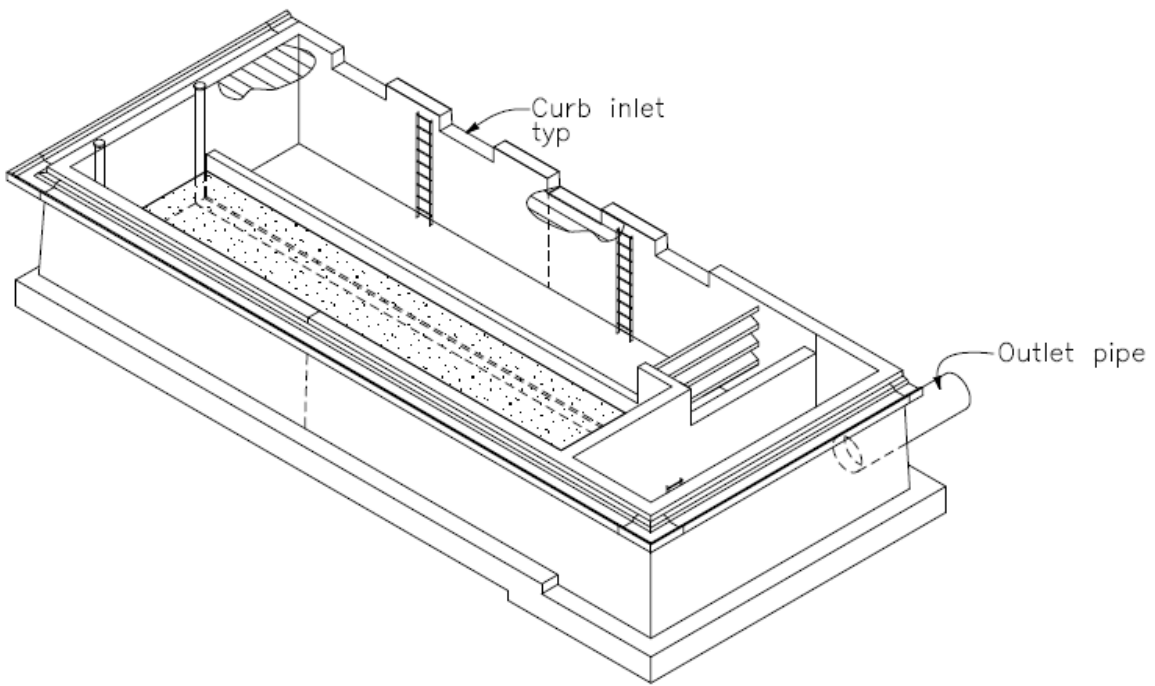

Figure 1-3. DSF Subtype 3 Isometric View



Table 1-1. DSF Subtypes and Selection Criteria

Subtype	Description	Selection Criteria
Subtype 1	Pipe Inlet and Pipe Overflow Structure	Inflow of surface runoff is made via a pipe inlet. This subtype is generally used when there are vector issues associated with the site or when the placement of the device requires entry of the runoff via pipe flow. Pipe flow must be at an elevation above that of the permanent pool. Overflow events are released from the sedimentation chamber through pipes in the wall connecting to the overflow chamber; this release mechanism requires more head than the weir overflow structure used in Subtype 2. A rubber check valve is used at the inlet pipe to seal off the device from the upstream drainage system when no flows exist, and a check valve is used on the overflow pipes at the downstream end. For vector proofing, both the inflow pipe and outflow pipe must be configured with check valves.
Subtype 2	Pipe Inlet and Weir Overflow Structure	Pipe inlet – Same criteria as Subtype 1. Overflow releases are made from the sedimentation chamber to the overflow chamber via a weir on the wall separating these chambers. This release mechanism requires less head than required from the Subtype 1. The overflow chamber in this subtype is provided with another divider wall for housing an outflow pipe with check valve. For vector-proofing, both the inflow pipe and the outflow pipe must be configured with check valves.
Subtype 3	Curb or Pipe Inlet and Weir Overflow Structure	Inflow of surface runoff is made via curb inlets or a pipe inlet. Due to construction tolerances, setting the vault curb openings at exactly the correct elevation to match the gutter flowline is very difficult. This subtype is generally used when there are no vector issues at the site, or when arrangements have been made with the local vector control agency for periodic inspection and vector control. The overflow chamber uses Subtype 1 criteria except that the overflow pipes are replaced with the weir overflow structure from Subtype 2

This page intentionally left blank.



Section 2

Basis of BMP Detail Drawings

DSFs should be considered for tributaries with a relatively high percentage of impervious area and low sediment loading. Additionally, the site must have sufficient hydraulic head for the filter to operate by gravity. DSFs can benefit from pretreatment BMPs.

Checklist T-1, Part 8 in the PPDG, assists in evaluating the initial feasibility of a DSF for a project. The checklist identifies design elements that should be considered during the design of media filters. Once the feasibility of the device has been confirmed using Checklist T-1, Part 8 in the PPDG, use the following subsections to further understand the feasibility of a DSF for a given site.

2.1 Design Basis

The primary design parameter for sizing a DSF is the WQV, which is the volume of runoff to be treated by methods listed in Section 3.1.1. When an upstream flow splitter is infeasible, the BMP is configured inline and the Design Storm flow (Q_d) parameter is also used for sizing.

The WQV determines the following DSF design parameters:

- Area of the filter chamber (A_{fc}) or sedimentation chamber (A_{sc}). A_{fc} and A_{sc} are equal
- Interior length of filter chamber (L_{fc}) or sedimentation chamber (L_{sc}). L_{fc} and L_{sc} are equal
- Interior width (W) of DSF's sedimentation chamber or filter chamber. Widths of the sedimentation and filter chambers are equal
- Design Water Depth (H_w) in the filter chamber above the filter media

The Q_d determines the following DSF design parameters:

- Diameter of the inlet and outlet pipes
- Size of the overflow pipe for overflow release (for Subtype 1)
- The total height of the structure needed above the invert of the overflow structure (weir or pipe)

Subsequently, the dimensions of the DSF, site topography, and existing and desired inlet and outlet elevations determine the range of allowable wall heights for the DSF vault. DSFs are intended to operate under gravity.

2.2 Design Criteria

DSFs must meet certain design criteria to perform as an effective TBMP. A set of DSF Detail Drawings (Caltrans 2020b) have been developed. These drawings assume an inline BMP configuration and can be obtained from OHSD. Table 2-1 presents the design criteria utilized for the development of the DSF Detail Drawings.

Parameter	Value
Filter media (sand layer)	Refer to Caltrans Permeable Material Non-Standard Special Provision (nSSP) Section 62, Class 5
Permeable material (gravel)	Refer to Caltrans Permeable Material RSS Section 62, Class 4
Filter fabric between filter media and permeable material layer	Refer to Caltrans Filter Fabric RSS Section 62, Type D
Depth of filter media	1.5 feet (ft) (typical)
Depth of permeable material layer	1.0 ft (minimum); varies to adjust longitudinal slope of the device
Underdrain pipe diameter	6 inches - Refer to Caltrans Standards Section 64 Plastic Pipe and 68 Subsurface Drains ¹
Longitudinal slope of sedimentation chamber	1%
Longitudinal slope of filter chamber underdrain	1%
Design drain time for WQV	Up to 96 hours
Void ratio of filter media	Typically 0.35
Coefficient of permeability of the filter media	1-2 inches/hour (Any variation from this range requires the approval of the Design SW Coordinator and the Maintenance SW Coordinator)
Vector proofing	<ul style="list-style-type: none"> Inlet/outlet pipes must be provided with rubber check valves (Refer to Table 1-1) Aluminum covers to control vector access

1. Alternative underdrain material, such as storage cell media, may be considered. See Section 6.9 for more detail.

The DSF Detail Drawings can be renamed and/or revised as necessary by the PE in responsible charge of the project. However, structural and non-structural changes must be discussed with OHSD and/or the Division of Engineering Services (DES). The drawings are intended for standard inline configuration designs under normal conditions and typical external loading requirements, which are outlined in the "General Notes", "Design Notes", and "Detail of Design Loading Cases", sections on the Legend of the drawings.

2.3 Special Designs

A Special Design will be required for sites or conditions that do not meet the standard design criteria listed in Table 2-1, such as:

- High ground water table (above the bottom of the concrete footing of the DSF)
- Surcharge loads that exceed the DES Underground Structures design criteria (LRDF)
- Inadequate bearing capacity
- Freeze-thaw or corrosive conditions
- Excessive or uneven settlement due to seismic or other causes

See Section 8 for more information on Special Designs.

2.4 Inline vs. Offline Placement

A DSF can be placed in an inline or offline configuration however, offline placement is preferred.

A. Inline Placement

A TBMP is placed in an inline configuration when an alternate route for flows greater than the Water Quality Event is not provided. Designing a TBMP in an inline configuration is not the preferred method but may be acceptable due to space restrictions.

Alternate means of safely conveying the events larger than the Water Quality Event must be provided. Additionally, the TBMP must be able to pass the runoff generated during the Design Storm (see Section 6.2) through the TBMP to downstream conveyance without objectionable backwater effects to upstream facilities or causing erosion. An overflow chamber or device is designed to convey the runoff from an overflow event (see Section 6.3).

B. Offline Placement

A TBMP is placed in an offline configuration when an alternate route for flows greater than the Water Quality Event is provided. The excess runoff is diverted around the TBMP to avoid exposing the treatment facility to events larger than the Water Quality Event. Flow diversion structures typically consist of flow splitters, weirs, orifices, or pipes to bypass excess runoff as discussed in Section 6.4. Even in an offline placement, overflow devices must be considered.

2.5 Safety Considerations

DSFs should be located using the general roadway drainage considerations for safety and CRZ concept in the AASHTO manual (AASHTO 2011). Traffic safety is an important part of highway drainage facility design. The DSF should provide a traversable section for errant traffic leaving the traveled way within the CRZ (HDM

Topics 304, 309, and 861.4). Coordinate with other functional experts such as District Traffic Operations, District Maintenance, District Hydraulics, Geotechnical Design, Structure Design, and Traffic Safety, as applicable.

Consult with District Traffic Operations for all proposed placements to determine if guard railing is required. DSFs should have detailing that preclude ready access by the public.

2.6 Restrictions/Coordination

Successful implementation and utilization of the DSF will require proper siting by the PDT in coordination with District Hydraulics, District Maintenance, District Traffic Operations, Geotechnical Design, Structure Design, and Traffic Safety, as applicable per site design. The DSF design decisions and coordination must be documented in the SWDR and project file.

Section 3

Getting Started

This section presents the design parameters and calculations necessary to support the sizing and selection of the appropriate standard, inline DSF. It is assumed that the need for a DSF has already been determined in accordance with the guidelines and procedures presented in Section 2 and in the PPDG. It is further assumed that the specific site for the BMP has been selected. As a result, no BMP selection or site selection guidelines are provided herein.

This guidance and the DSF Detail Drawings assume that the DSF is configured inline. Additionally, alternative sizing calculations may be used to refine the BMP size. When an offline configuration or alternative sizing calculations are used a Special Design may be necessary, see Section 8.

3.1 Preliminary Design Parameters

To utilize the DSF Detail Drawings, the following design parameters are needed.

- **WQV:** The WQV is calculated using the methodology in Section 3.1.1.
- **Design Storm Flow (Q_d):** The Q_d is calculated consistent with the intensity, duration, and frequency of the rainfall event used in the roadway drainage design for that contributing drainage area (CDA) as discussed in HDM Topic 831.
- **Hydraulic Head (h_d):** The h_d is defined as the elevation difference between the invert of the inlet pipe and invert of the outlet pipe of the DSF.
- **Design Water Depth (H_w):** The H_w is defined as the maximum depth of the water above the filter media in the filter chamber for a specified WQV. This is the vertical distance between the crest/invert of the overflow structure and top elevation of the filter media of the filter chamber. Refer to Figure 3-1 for dimensional relationship. Design Water Depth is not the same as the maximum water surface, which is only reached during an overflow event that exceeds the WQV. The total height of the walls will be equal to the maximum water depth during an overflow event plus the freeboard (1 foot) above the maximum water surface.
- **Headwater Depth for Overflow Structure (Weir or Pipes) (h_o):** The h_o is defined as the headwater depth above the crest of the overflow weir or invert of the overflow pipes during release of Q_d . Its base is coincident to the H_w elevation. Refer to Figure 3-1 for dimensional relationship.
- **Freeboard (h_f):** The h_f is defined as the depth (minimum 12 inches) that should be provided between the highest surface water elevation in the sedimentation chamber during the Design Storm and top of outside wall elevation. The beams

supporting the cover for the DSF can be inundated during the overflow release events.

- **Overflow Pipe(s) Diameter (d_o):** The d_o is the diameter of the overflow pipe that is used in lieu of the overflow weir structure (DSF Subtype 1).
- **Stick-up Height (h_s):** This is the height of the structure above the finished grade. A minimum of 6 inches of stick-up height is recommended.

3.1.1 Contributing Drainage Area and WQV

The WQV generated by the BMP CDA is calculated using the Small Storm Hydrology Method (PPDG Section 5.3). An explanation of CDA delineation and WQV calculation and example can be found in Section 3 of the DPPIA Design Guidance (Caltrans 2019a).

3.2 Preliminary Calculations

3.2.1 DSF Design Procedures

The DSF design procedure is presented below in seven steps. This procedure was used to set the dimensions for the device as shown on the DSF Detail Drawings. The design procedure presented in this section can be omitted if a special DSF design is not required and the PE selects a standard DSF from the DSF Detail Drawings (Legend) or Table 3-1.

Step 1: Calculate Filter Chamber Area (A_{fc})

$$A_{fc} = [C_f \times WQV \times d_f] / [k \times T \times (h + d_f)]$$

Step 2: Calculate Sedimentation or Filter Chamber Length

$$L_{sc} = L_{fc} = A_{fc} / W$$

Step 3: Calculate Storage Volume in Filter Voids

$$V_v = V_r \times A_{fc} \times (d_f + d_g)$$

Step 4: Calculate Flow-through Filter during Filling

$$V_Q = [k \times A_{fc} \times (d_f + d_g) \times t_f] / d_f \times C_f$$

Step 5: Calculate Net Volume Required to be Stored in Chambers Awaiting Filtration

$$V_{ST} = WQV - V_v - V_Q$$

Step 6: Calculate Available Storage in Sedimentation and Filter Chambers

$$V_{SF} = 2h \times (A_{fc} + A_{sc})$$

Step 7: Compare V_{SF} and V_{ST}

If $V_{SF} > V_{ST}$, proceed with the design

If $V_{SF} < V_{ST}$, adjust the length, width, or design water depth of either chamber, and repeat Steps 1 through 6

Where:

A_{fc} = area of filter chamber; A_{fc} is equal to the area of sedimentation chamber (A_{sc})

C_f = conversion factor for coefficient of permeability (12 for inches to ft)

d_f = depth of filter media (18 inches)

d_g = depth of permeable material layer (12 inches minimum)

k = coefficient of permeability of the filtering medium (1 inch/hour)

T = design drain time for WQV (96 hour)

h = average water height above the surface of the media bed = $H_w/2$

L_{sc} = length of the sedimentation chamber; L_{sc} is equal to the length of filter chamber (L_{fc})

W = selected width for filter chamber or sedimentation chamber (this is not the total width of DSF)

t_f = time to fill the voids, one hour

V_r = void ratio

V_{ST} = storage volume in filter voids

V_Q = volume of water passing through filter during time to fill voids

V_V = volume of voids in the filter media and permeable material layer

V_{SF} = available storage in the sedimentation and filter chambers

3.2.2 DSF Dimensions

After calculating the WQV, Table 3-1 should be used to select a standard DSF type. Figure 3-3 shows a plan and section view of a DSF (Subtype 2) to present dimensional relationships. Table 3-1 is based on the design procedure provided in Section 3.2.1 and DSF Detail Drawings.

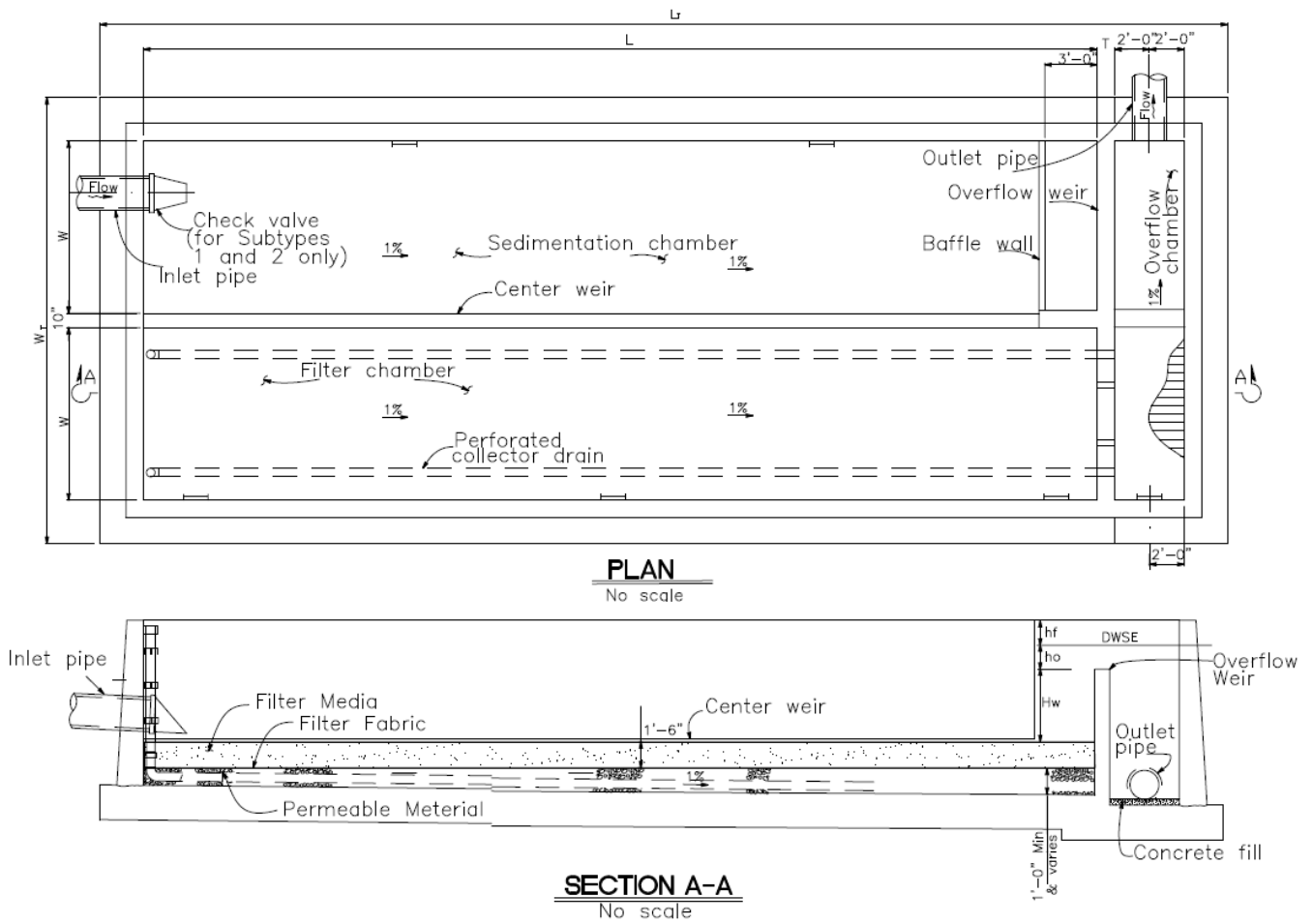

Figure 3-1. DSF Dimensional Relationship (Subtype 2)

Table 3-1. DSF Sizing Summary

DSF Type	WQV Range ft ³	W ft	L ft	H _w ft	W _T		L _T		h _d ft	d _f ft	d _{g-u/s} ft	d _{g-d/s} ft
					H ≤12'	H ≤14'	H ≤12'	H ≤14'				
S-3500	3,500-4,000	10'	55'	3'	25'-10"	26'-4"	65'-0"	65'-8"	3'-9"	1'-6"	1'-0"	1'-7"
L-3500	3,500-4,000	6'	75'	4'	17'-10"	18'-4"	85'-0"	85'-8"	3'-11"	1'-6"	1'-0"	1'-9"
S-5000	4,001-6,000	10'	75'	3'	25'-10"	26'-4"	85'-0"	85'-8"	3'-11"	1'-6"	1'-0"	1'-9"
L-5000	4,001-6,000	6'	110'	4'	17'-10"	18'-4"	120'-0"	120'-8"	4'-3"	1'-6"	1'-0"	2'-1"
S-7500	6,001-8,500	15'	75'	3'	35'-10"	36'-4"	85'-0"	85'-8"	3'-11"	1'-6"	1'-0"	1'-9"
L-7500	6,001-8,500	10'	90'	5'	25'-10"	26'-4"	100'-0"	100'-8"	4'-1"	1'-6"	1'-0"	1'-11"
S-10000	8,501-11,000	15'	75'	5'	35'-10"	36'-4"	85'-0"	85'-8"	3'-11"	1'-6"	1'-0"	1'-9"
M-10000	8,501-11,000	15'	90'	4'	35'-10"	36'-4"	100'-0"	100'-8"	4'-1"	1'-6"	1'-0"	1'-11"
L-10000	8,501-11,000	15'	110'	3'	35'-10"	36'-4"	120'-0"	120'-8"	4'-3"	1'-6"	1'-0"	2'-1"
S-12500	11,001-13,500	15'	90'	5'	35'-10"	36'-4"	100'-0"	100'-8"	4'-1"	1'-6"	1'-0"	1'-11"
L-12500	11,001-13,500	15'	110'	4'	35'-10"	36'-4"	120'-0"	120'-8"	4'-3"	1'-6"	1'-0"	2'-1"
S-15000	13,501-15,000	15'	110'	5'	35'-10"	36'-4"	120'-0"	120'-8"	4'-3"	1'-6"	1'-0"	2'-1"
L-15000	13,501-15,000	15'	130'	4'	35'-10"	36'-4"	140'-0"	140'-8"	4'-6"	1'-6"	1'-0"	2'-4"

Where:

W = inside width of the DSF chambers (sedimentation or filter chamber)

L = inside length of the DSF chambers (excluding the length of the overflow chamber)

H_w = water depth above the filter media up to the crest/invert of the overflow device

H = wall height of the DSF

W_T = total width of the DSF including wall thickness and center weir width

L_T = total length of the DSF including wall thickness and length of the overflow chamber

h_d = hydraulic head across the DSF inlet to the outlet. It should be noted that the h_d listed in Table 3-1 is for DSF Subtype 1, Subtype 2, and Subtype 3 with pipe inlets. h_d required for Subtype 3 (curb inlet)

would be equal to the sum of freeboard (h_f), headwater depth required for overflow structure (h_o), Design Water Depth (H_w), and depth of filter media and permeable material layer in the filter chamber.

d_f = depth of filter media (sand layer)

$d_{g-u/s}$ = depth of permeable material layer on the upstream side of the DSF

$d_{g-d/s}$ = depth of permeable material layer on the downstream side of the DSF

The following is the rationale used for developing the WQV ranges:

1. Limited the number of configurations to three sets of wall widths and four sets of wall lengths. The actual dimensions were slightly modified to fit all the WQV models.
2. Assigned WQV ranges between 3,500 to 15,000 CF.

Selected an upper WQV range based on a reasonable higher WQV value and for the following reasons:

1. DSF designed with the criteria to fill voids in one hour estimated storage based on how much volume can be released in one hour plus volume of voids. This allows more volume in the DSF chamber in one hour.
2. DSF may take longer than one hour to fill and will result in a higher volume available for storage and treatment.
3. Design is based on the permeability of the filter just prior to replacing the filter media.

Although it was not the criteria to use available storage after one hour of operation to select the "upper WQV range", this gives more flexibility in treating WQV in the device.

Each DSF type designation consists of the following:

- Length Configuration (S, M or L): Either a short (S), medium (M), or a long (L) configuration can be selected, depending on the footprint of the available land. The length-to-width ratios of the S and L configurations are approximately 2:1 and 5:1, respectively
- The width W in Table 3-1 is the inside clear width of the sedimentation chamber and filter chambers. The total width W_T of each DSF type includes W for each chamber, the central weir width, and wall thicknesses
- WQV: For most projects, an upper limit of 15,000 CF is expected to meet the required treatment. A Special Design would be required for a WQV higher than the upper limit

Acceptable design values for hydraulic conductivity (coefficient of permeability) typically range from one to two inches per hour. This range is conservative. These values are based on relatively clogged filters, which is when maintenance should occur. These commonly used values for sand filters consider the layer of accumulated sediment on the surface of the filter. This layer controls the low coefficient of permeability, not the media itself.

The WQV ranges shown in Table 3-1 are for a coefficient of permeability of one inch per hour. When site conditions warrant the use of a smaller BMP footprint, a coefficient of permeability of two inches per hour or more may be considered, which doubles the volume ranges shown in Table 3-1. Use engineering judgment prior to increasing the coefficient, including project specific considerations such as amount of sediment load that will enter the BMP. Smaller filters may clog sooner and require more frequent cleaning. Obtain approval from the Design/Regional Design Stormwater Coordinator and the Maintenance Stormwater Coordinator.

3.2.3 DSF Wall Heights

After the length and width of the DSF have been determined, the wall heights and footing elevations must be calculated according to the procedure presented in Section 4. The wall heights are used to determine the Design H values which determine the quantities of concrete, steel rebar, and excavation for the walls and footing.

3.2.4 Inlet and Outlet Structure

As mentioned in Section 1.1, there may be two types of inlets in a DSF: pipe inlet (DSF Subtype 1, Subtype 2, and Subtype 3), and curb inlet (DSF Subtype 3).

3.2.4.1 Pipe Inlet and Pipe Outlet

The inlet/outlet pipe diameter of the DSF could match the existing influent or outlet pipe diameter if the site is retrofitted for installing a DSF. However, for new construction, the DSF inlet/outlet pipe should be designed for the Design Storm, Q_d . A detailed analysis should be performed for flow entering the device when upstream bypass is provided. There may be several scenarios of flows based on the site conditions such as unsubmerged partially full, unsubmerged full, or submerged full inlet/outlet pipes. Evaluate the conditions and determine which methods apply for the design. The following hydraulic equations/methodologies can be used for sizing the inlet/outlet pipe.

1. Manning's equation can be used if the pipe is unsubmerged and flowing partially full.

$$V = \frac{1.49 \times R^{2/3} S^{1/2}}{n} = \frac{Q}{A}$$

2. Inlet control culvert equation or hydraulic nomograph can also be used when the inlet or outlet pipe (downstream) is unsubmerged. Refer to design methodologies and hydraulic nomographs for inlet control culvert flow presented in Federal Highway Administration (FHWA) Hydraulic Design Series (HDS) No. 5 (FHWA 2001) if this scenario governs.
3. Outlet control culvert equation or hydraulic nomograph can be used when the inlet or outlet pipe is submerged. Refer to design methodologies and hydraulic nomographs for outlet control culvert flow presented in HDS No. 5 if this scenario governs.
4. Hydraulic software packages approved by Caltrans may also be used. See HDM Topic 866.4 Water Surface Profiles, and Topic 808.

3.2.4.2 Curb Inlet

The DSF Subtype 3 can also be equipped with curb inlets along the longitudinal side of the DSF. The curb height required is determined using the weir equation with curb-opening inlets without depression as shown below (FHWA 2009, Equation 4-30)

$$Q_d = CLh_o^{3/2}$$

Where:

Q_d = cubic feet per second (cfs) is the Design Storm flow rate through the curb inlet

L = (ft) is the length of the curb inlet

h_o = (ft) is the head required above the curb inlet

C = is weir coefficient = 3.0

g = (ft per second [ft/s²]) is the acceleration due to gravity = 32.2 ft/s²

$$Q_d = 3.0 Lh_o^{3/2}$$

3.2.5 Overflow Structure and Headwater Depth

Two types of overflow structures are designed for DSFs on the downstream end of the sedimentation chamber: 1) overflow weir, and 2) overflow pipe.

3.2.5.1 Overflow Weir

The head required above the weir crest could be calculated based on the sharp crested weir, with no end contractions, formula given below (FHWA 2009, Equation 8-19).

$$Q_d = C_w L_w h_o^{3/2}$$

Where:

Q_d = (cfs) is the Design Storm flow rate over the weir

L_w = (ft) is weir crest length

h_o = (ft) is the head above the weir crest excluding velocity head

C_w = is a coefficient; $C_w = 3.27 + 0.4 (h_o / H_c)$; for $h_o / H_c < 0.3$, $C_w = 3.33$

H_c = is the height of the weir from the top of the floor slab of sedimentation chamber

g = (ft/s²) is the acceleration due to gravity = 32.2 ft/s²

$$Q_d = 3.33 L h_o^{3/2}$$

3.2.5.2 Overflow Pipe

In general, the overflow pipes are designed by inlet control culvert equations. Refer to design methodologies and hydraulic nomographs for inlet control culvert flow presented in HDS No. 5.

3.2.6 Sedimentation Chamber Baffle Wall

A baffle wall is placed at approximately 3 ft upstream of the overflow structure to prevent litter release downstream. The baffle wall should be placed such that it is 6 inches below the top of the central weir. The velocity between the baffle wall bottom and the sedimentation chamber invert can be determined for the Design Storm flow (Q_d) event to check the scouring potential at the sedimentation chamber bottom. A Flow Splitter can be provided or a larger DSF type from Table 3-1 can be used to reduce the Design Storm flow velocity and to prevent scouring. Use the baffle wall as shown on DSF Detail Drawings. However, if a different baffle wall material is considered or location of the baffle wall needs to be shifted for the site conditions, contact OHSD.

This page intentionally left blank.



Section 4

BMP Selection

The method for selecting the most appropriate DSF size and configuration for a given site will often be an iterative process where several design factors presented in Section 3 are evaluated jointly. Figure 4-1, presents the typical process flowchart for selecting the most appropriate DSF size and configuration for a specific project. Selecting which DSF to use for a project is a four-step process with each step being discussed in detail below.

This guidance and the DSF Detail Drawings assume that the DSF is configured inline. Additionally, alternative sizing calculations may be used to refine the BMP size. When an offline configuration or alternative sizing calculations are used a Special Design may be necessary, see Section 8.

4.1 Review Site Conditions

Review site conditions to ensure that none of the site restrictions discussed in Section 2 are present, and to confirm that there is enough unobstructed area available for placement of a DSF. When siting the DSF, carefully consider construction access, the total width (W_T) of the DSF, formwork and expected limits of excavation, and maintenance access requirements. For WQV greater than 15,000 CF, consider a Special Design (see Section 8).

4.2 Select DSD Type and Configuration

After calculating the WQV, determine the proper DSF size by using Table 3-1. Table 3-1 primarily shows two different DSF configurations for each WQV range (except for 10,000 CF, which includes a third configuration. If either the short, medium, or long configuration fits inside the available footprint, evaluate which configuration is economical for construction. If the WQV is outside the range of values in Table 3-1, a Special Design may be required for the site (see Section 8).

Select the proper row in Table 3-1 by finding the WQV and select either the S, L, or M configuration and obtain the following dimensions:

- Interior width (W) of the sedimentation and filter chambers
- Interior length (L_s) of the sedimentation chamber
- Interior length (L_f) of the filtration chamber
- Design water depth (H_w)
- Depth of filter media (d_f) and permeable material layer ($d_{g-u/s}$ and/or $d_{g-d/s}$)
- The minimum required hydraulic head (h_d) for the appropriate DSF type

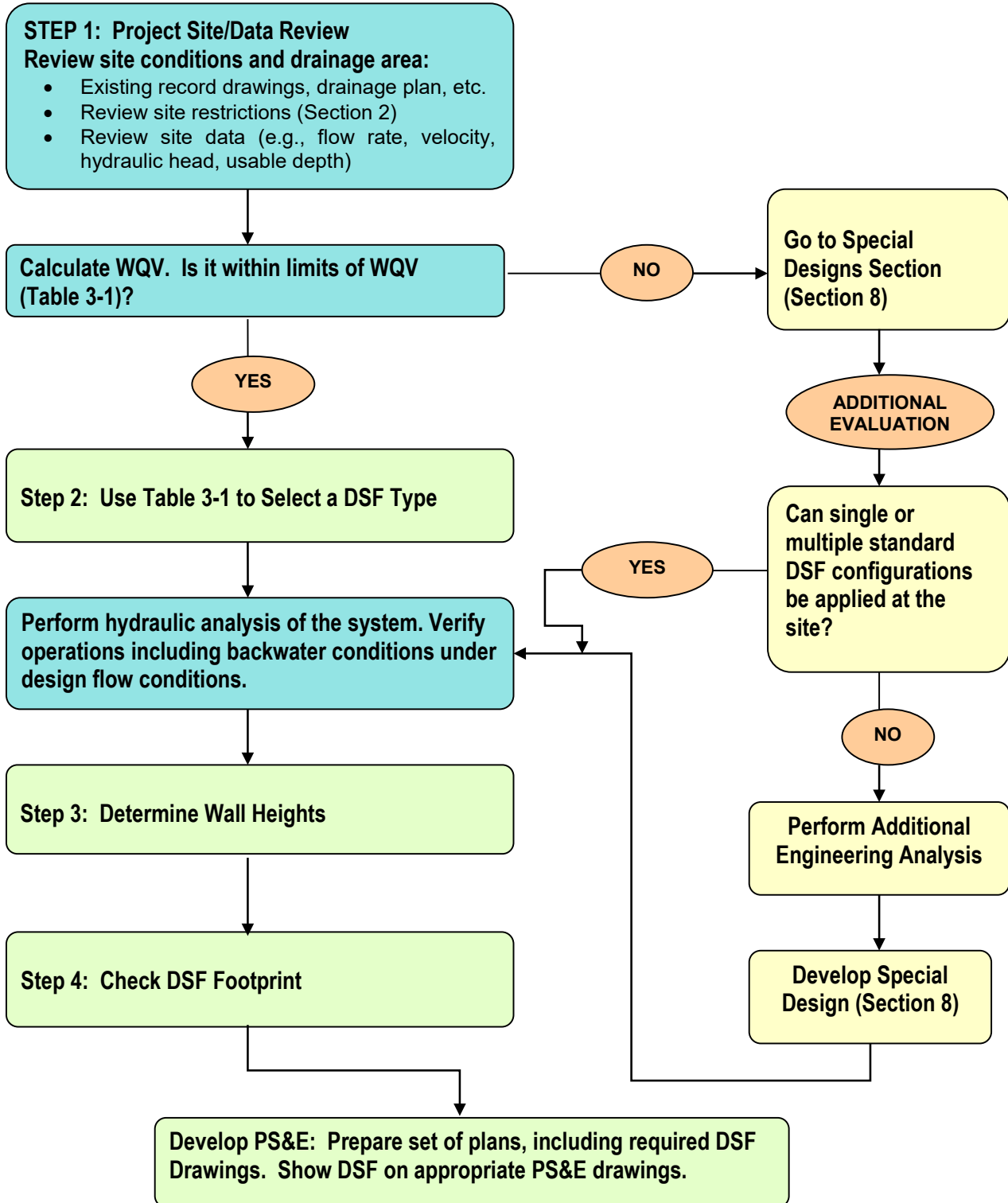

Figure 4-1: Typical DSF Selection Flow Chart

Set the invert elevation of the inlet pipe based on the site conditions. Compare the outside structure dimensions to the available footprint to determine if the DSF will fit. If it doesn't, try the other configuration for the calculated WQV. If neither configuration fits, a Special Design is needed.

Also, compare the minimum hydraulic head, h_d , to the head available at the site. The head available is the difference between the invert elevation of the DSF inlet and flow line elevation of the downstream drainage system where DSF outlet is to be connected. If the h_d is more than the head available, determine if the slope of the upstream drainage system can be reduced to achieve the h_d without impacting the upstream drainage system efficiency or determine if the downstream pipe can be adjusted using hydraulic analysis. The final step is to estimate if the device results in backwater conditions on the upstream drainage system. The upstream drainage system should satisfy the minimum freeboard requirements in the catch basins or drop inlets. Additionally, the upstream system should be evaluated for sedimentation because of backwater. If the above conditions cannot be satisfied, a Special Design is needed.

After obtaining the design parameters from Table 3-1, perform the following calculations:

- Calculate the head needed (h_o) above the overflow weir or overflow pipe for the Design Storm flow (Q_d)
- Select an appropriate freeboard (h_f) in the DSF (a minimum of 1 foot is recommended)
- Provide 4 inches of elevation drop (h_{fo}) between the sedimentation/filter chambers, and the overflow chamber
- Calculate the inlet pipe diameter required at Q_d or use the existing storm drain pipe diameter if retrofitting the existing system
- Determine the DSF outlet invert elevation by using an appropriate pipe slope between the DSF outlet and the downstream drainage structure at the point of connection
- Calculate the DSF inlet invert elevation by adding h_d to the outlet invert elevation

Calculate the Design Water Surface Elevation (DWSE) for the DSF or Hydraulic Grade Line for the site storm drain system at the DSF location based on site conditions and the minimum required freeboard at the stormwater collection and conveyance system at the site. The HDM, Chapter 830 Topic 837.4 should be used to determine the minimum freeboard required at the upstream catch basins.

- Based on the DWSE, determine if any drainage adjustments are needed, (refer to Section 9 for DSF Example for possible adjustments)



4.3 Determine DSF Wall Heights and Total Depth

The wall heights are determined using the procedure below. Refer to Figure 4-2, for assistance with this step. In addition, refer to Layout Nos. 1 and 2, of the DSF Detail Drawings for dimensions of the DSF.

- Layout the selected DSF model on the base map in the area where it is planned to be constructed considering site conditions
- Obtain the finished grade (FG) elevations at four corners of the DSF that correspond to the inlet and outlet sides of the DSF as shown in Figure 4-2
- Establish the top of the wall elevations at the four corners (WE1, WE2, WE3, and WE4) at 0.5 ft (stick-up height, h_s) above their corresponding FG elevations. If the FG elevations at the DSF corners are different, establish the top of wall elevations at all corners at 0.5 ft above the highest FG elevation
- Calculate the footing elevations (FE1, FE2, and FE3) at the four corners of the DSF (Refer to Layout No. 1 of the DSF Detail Drawings). Note that FE1 corresponds to WE1 and WE4, FE3 corresponds to WE2 and WE3, and FE2 corresponds to an intermediate point at the overflow weir or pipe wall location. Obtain the footing elevations (FE1, FE2, and FE3) by subtracting the sum of hydraulic head for overflow weir or pipe (h_o), headwater depth (H_w), depth of filter media (d_f), and depth of permeable material layer ($d_{g-u/s}$ or $d_{g-d/s}$ as appropriate) from the DWSE. It should be noted that the footing depth varies with the wall height.
- Calculate wall heights at the four corners of the DSF by subtracting the footing elevation from the top of the wall elevations. This would be the design H for the DSF. For height greater than 14 ft, special wall design is required. PE shall coordinate with Structures to develop the structural design of the wall.
- Determine if 12 inches of freeboard (h_f) is available (refer to Figure 3-1)
- For Subtype 1, determine if a minimum of 6 inches is available between top of wall elevation and top of overflow pipe. Refer to Layout No. 2 of the DSF Detail Drawings.
- Determine the total depth (D) of the DSF by adding the depth of the footing (d_{ft}) to the Design H values. Refer to Footing Details of the DSF Detail Drawings for d_{ft} .
- Determine total length (LT) of the DSF including wall thickness and length of the overflow chamber
- Determine total width (WT) of the DSF including wall thickness and center weir width

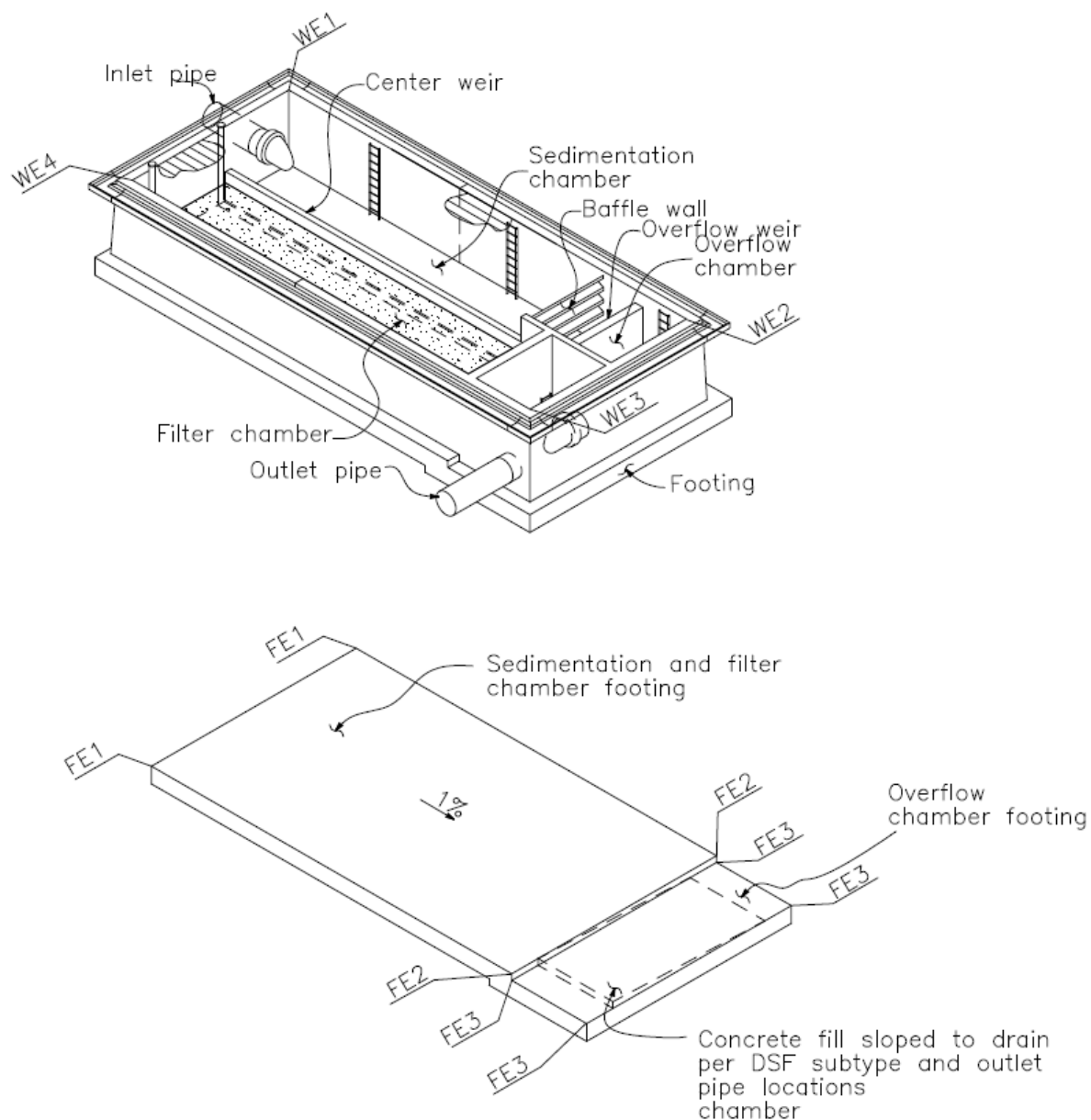

Figure 4-2. DSF Wall Height Determination

4.4 Check DSF Footprint

This step is to calculate the total length (L_T) and total width (W_T) concrete dimensions of the selected DSF type to the available footprint of the site. Use Table 3-1, to determine L_T and W_T of the DSF. It should be noted that L_T and W_T vary with the Design H. Check length and width against the available footprint at the site. In the event selected DSF does not fit on the site, identify the potential constraints, select another model that might fit on the sight for a lower WQV, or coordinate with Structure Design to develop a Special Design for the site-specific conditions.

This page intentionally left blank.



Section 5

BMP Layout

This section discusses various considerations needed to place a DSF within the project, including layout, space and construction requirements, and detailing of the conveyances carrying runoff into and away from the devices.

5.1 DSF Layout

The layout of the DSF is set by aligning the device in the direction of the incoming flow, and by adhering to the limitations of the DSF design. The orientation of DSF may be rotated up to 90 degrees from what is shown on the DSF Detail Drawings. The inlet can enter the DSF from either of the two external side walls of the sedimentation chamber. A “T” or “L” fitting is recommended if the flow enters perpendicular to the external side walls of the sedimentation chamber for distributing flow inside the sedimentation chamber. The outlet pipe can also be positioned at any of the three external side walls of Subtype 1 and 3, and at two external walls of Subtype 2 of the overflow chamber.

Based on the topography of the site, backfilling may be required at the DSF site. Backfill to prevent sliding should not exceed 2 ft in elevation difference between side walls and end walls. The layout of the DSF must consider the structure’s footprint L_T and W_T concrete dimensions (DSF Detail Drawings) in relation to the available site footprint, as well as the existing inlet and outlet drain pipe layout in relation to the DSF requirements.

5.2 Space Considerations

DSFs require sufficient space and/or access for maintenance and inspection, including the use of vacuum trucks and other equipment for cleaning and media replacement. The proposed DSF locations should be verified with District Maintenance to confirm the space and access availability for maintenance and inspection of the structure. The DSF should be located outside the CRZ (HDM Topic 309.1). Consult with District Traffic Operations to determine if guardrail is required.

5.3 Construction Requirements and Restrictions

Construction requirements for DSFs are specified in the DSF Detail Drawings and accompanying Special Provisions (see Sections 7.1 and 7.2).



5.4 Inlet and Outlet Pipe Diameter

The inlet pipe and outlet pipe can penetrate the DSF at a skew angle with a maximum angle of 45 degrees and a maximum diameter of 2.83 ft with maximum opening of 4 ft in the side wall (Refer to Exterior Wall Details of DSF Detail Drawings). In general, the inlet and outlet diameters of the DSF should match those for the existing influent and effluent stormwater pipes at a site.

5.5 Hydraulic Head

For proper operations, hydraulic head (h_d) required should be consistent with Table 3-1 for a DSF type. Verify that required water storage for the WQV is available above the filter media in the DSF in addition to the required h_d . If the h_d available between the inlet invert and outlet invert of the DSF is less than the h_d required for a DSF type, a special design would be required. However, if the h_d available is greater than the h_d required, special DSF design would not be required. In this instance, a drop structure can be provided at the inlet or the outlet, depending on site conditions.

Section 6

Design Elements

The DSF Detail Drawings are a complete set of structure plans, and do not require additional items of work or features for their operation. However, certain supplemental structures and devices may be required in the construction of DSFs. These supplemental design elements are discussed in detail in the Supplemental Details Design Guidance (Caltrans 2020c). It is the PE's responsibility to determine which of the DSF supplemental design elements are required for a specific site.

6.1 Maintenance

Discuss proposed DSF location and access with the District Maintenance Stormwater Coordinator, as maintenance is critical to these devices. Provide vehicle access around the DSF to adequately and safely allow access to all structures and devices located within the vault area. Maintenance access roads, if required, must be located within Caltrans right-of-way or within a maintenance easement and must be able to accommodate all sizes of vehicles to cover routine visits; they must allow for trash and debris removal, possibly using a vacuum truck. Coordinate with District Maintenance Stormwater Coordinator on maintenance access to the device.

6.2 Design Storm

Both storm volume and peak flow conditions must be considered in the evaluation of runoff conditions. The Design Storm is the event that generates runoff rates or volumes that the drainage facilities are designed to handle (see HDM, Topic 831). For this guidance manual, the term Design Storm is used in reference to designing drainage facilities and refers to the peak drainage facility design event as determined in accordance with the HDM¹.

6.3 Overflow Events

It is preferred that the DSF be designed offline, where flows exceeding those associated with the WQV are diverted around the DSF through an upstream flow splitter. When a flow splitter is not feasible, the DSF may be designed online, where

¹ For convenience in this document, the Design Storm flow is referred to as Q_{25} . However, other recurrence intervals may have been used for the roadway drainage design, as described in HDM Chapter 830, Transportation Facility Drainage; confer with District Hydraulics.

flows are designed to travel through the DSF with release through an overflow device.

6.4 Overflow Devices

When placed inline, the DSF must safely pass events that exceed the WQV. Overflow devices must also be considered for offline placement if clogging of the upstream flow splitter or other unusual conditions occur. The overflow device for a DSF is often an overflow chamber. The release elevation should be set to the surface of the WQV.

The overflow device shall meet the design criteria and be accompanied with downstream conveyance engineered to handle the Design Storm flow. In addition, a minimum freeboard of 12 inches should be provided between the surface water elevation during the overflow event and the lowest elevation of the confinement in order to provide assurance of the physical integrity of the TBMP and downstream facilities.

6.5 Flow Splitters

Flow splitters are upstream drainage bifurcation structures designed to direct inflows corresponding to the treatment volume to TBMPs and to divert peak flows. Possible conditions requiring the implementation of a flow splitter in conjunction with an TBMP are listed below:

- Backwater effect in the TBMP
- Large peak storm effects
- Inlet/Outlet pipe elevation constraints
- Available capacity of overflow device discharge connection
- Downstream effects of an overflow device

A detailed hydraulic analysis will be required to properly size and design the flow splitter structure, which is covered in the Flow Splitters Design Guidance (Caltrans 2020d).

6.6 Excessive Flows

In addition to implementing flow splitters as described above, in cases where the WQV of a drainage area would require a DSF footprint larger than what is available, consider either requesting a smaller WQV event depth from the Regional Water Quality Control Board or splitting a large drainage area into sections and using additional DSFs in series or in parallel arrangements. However, parallel arrangements may result in operational issues, and the preferred method would be the placement of a single DSF to serve an entire tributary area.

6.7 Upstream Effects

While DSFs are placed for water quality purposes, they must also operate safely and effectively as part of the overall highway drainage system. Hydraulic design issues must be carefully evaluated during the design process. The BMP placement and design must consider the design of the roadway drainage system.

When placed inline, the Design Storm must be determined and the associated hydraulic grade lines calculated to ensure that placement of the device does not impede the effective drainage of the roadway. Additional discussion of those analyses are beyond the scope of this document and should be coordinated with District Hydraulics.

6.8 Potential Downstream Impacts

Potential downstream impacts must be considered. Placement of this or any other TBMP must not cause objectionable headwater or violate requirements of Chapter 800 of the HDM. Specific consideration of the overall placement within a particular drainage system is beyond the scope of this document and should be coordinated with District Hydraulics.

6.9 Underdrain System

Typical underdrain systems consist of perforated underdrain pipe, surrounded by permeable material, and covered by a geotextile material. The underdrain system conveys treated runoff to the downstream discharge while allowing infiltration through native soil, as applicable. Underdrain systems can be designed using high-void-space materials, or storage cell media, as an alternative to perforated underdrain pipe and permeable material.

Storage cell media are proprietary modular systems that typically consist of a network of hard-perforated, interconnecting mats that are encased in geotextile filter fabric. The filtered runoff is collected by the storage cell media and then infiltrated into the native soil or is discharged to a downstream conveyance. Storage cell media requires less head and when used in a non-structural underdrain system, the storage cells media is not required to be traffic rated.

The use of storage cell media within an underdrain system must be coordinated with the District/Regional Design Stormwater Coordinator, Geotechnical Design, District Maintenance Stormwater Coordinator, and OHSD, as appropriate. Consult with HQ Department of Environmental Analysis (DEA) and OHSD for underdrain system design approval or to determine if a Special Design or pilot is required.

6.10 Litter and Trash Considerations

Caltrans has developed a Statewide Trash Implementation Plan (Plan; Caltrans 2019c) to prevent the discharge of trash to surface waters through stormwater discharges. The Plan identifies statewide Significant Trash Generating Areas (STGAs) requiring consideration of full trash capture BMPs.

Full trash capture should be included in the design of an AVSF within a watershed where any of the following exists:

1. A Total Maximum Daily Load (TMDL) restriction for trash
2. Discharges to a 303(d) listed waterway for trash
3. Has been identified as an STGA
4. Required by a Regional Basin Plan

The AVSF is a Caltrans approved treatment device that can be certified as a multi benefit full trash capture BMP. The full-capture volume is calculated using the 1-year, 1-hour storm event depth. Refer to the Multi Benefit Treatment BMP Trash Full Capture Requirements Design Guide (Caltrans 2018a) for specifics on design details.

Additionally, the PE may include a pretreatment device to capture the gross solids (e.g., paper, plastics, glass) and naturally occurring debris that may be conveyed by stormwater to the AVSF. The device should be designed to remove all litter and solids 5 mm and larger. This pretreatment can be provided by the Caltrans approved Gross Solids Removal Devices (GSRDs) TBMP or other devices that meet the requirements for full trash capture.

Use of other devices requires a detailed design by the PE and must be coordinated with the District/Regional Design Stormwater Coordinator, District Hydraulics, Traffic Safety, District Maintenance Stormwater Coordinator, and OHSD, as appropriate. Consult with DEA and OHSD for design approval or to determine if a Special Design or pilot is required. Design decisions and coordination on the trash device must be documented in the SWDR.

Section 7

PS&E Preparation

This section provides guidance for incorporating DSFs into the PS&E package, discusses the typical specifications that may be required, and presents information about estimating the construction costs.

While every effort has been made to provide accurate information here, the PE is responsible for incorporating all design aspects of DSFs into the PS&E in accordance with the requirements of Section 2 of the Construction Contract Development Guide (Caltrans 2019d).

7.1 PS&E Drawings

This section provides guidance for incorporating the DSF Detail Drawings into a PS&E package. The PE is responsible for incorporating the DSF design into the PS&E in accordance with the procedures typically followed when developing a PS&E package. For example, the applicable layout, grading, drainage, and detail sheets should be updated to reflect the required design features of the DSF with the appropriate references to incorporate the DSF Detail Drawings into the PS&E package.

The PS&E drawings that require development due to the inclusion of a DSF may include the following:

- **Layout(s):** Show the location of the DSF and callout standard DSF configuration types. This is a recommended option, as its use will aid in recognizing, both within and outside Caltrans, that DSFs were placed within the project limits.
- **Grading or Contour Grading Plan(s):** Associated grading surrounding the DSF should be shown on these sheets.
- **Drainage Plan(s), Profiles, Details, and Quantities:**
 - The Drainage Plan sheets should show the DSF in plan view. Other existing or proposed drainage conveyance devices that direct the runoff into the device should also be shown.
 - The Drainage Profile sheets should show the DSF in profile within the drainage conveyance system. These sheets should also call out the specific inlet and outlet flow line (surface) elevations, as well as the trench invert elevation. Call out specific DSF pipe inlet and outlet flow line elevations.
 - The Drainage Detail sheets show the details as needed to construct or clarify interface points. Most of the required information is included on the DSF Detail Drawings. These drawings should be included with the Drainage Details section of the PS&E. Estimate the number of overflow pipes needed for the

sedimentation and chamber and include that on the Details. Other details may be necessary to adequately reflect the required improvements.

- **Temporary Water Pollution Control Plans:** These sheets are used to show the temporary BMPs used to establish the DSF BMPs and compliance with the Construction General Permit.

7.2 Specifications

Contract specifications for projects that include DSFs may include a combination of Standard Specifications, Standard Special Provisions (SSPs), and may include nSSPs. In some cases, specific nSSPs have been developed by OHSD. In some cases, specific nSSPs have been developed by OHSD.

Special provisions for the various items of work needed to construct the DSF could be organized under an umbrella 'DSF' nSSP with the required items listed as subheadings. Payment would be by 'each' DSF.

Optionally, separate listings could be made for each contract item of work, with separate measurements and payments. The PE and the District Office Engineer should consider which method would better serve the project.

7.2.1 Standard Specifications

Listed below are Standard Specifications that would typically be used for a project that constructs a DSF. Consider the construction of the DSF in the context of the entire project to determine if other Standard Specifications may be required.

- 13 Water Pollution Control
- 15 Existing Facilities
- 17 General (Earthwork and Landscape)
- 19 Earthwork
- 20 Landscape
- 21 Erosion Control
- 26 Aggregate Bases
- 39 Asphalt Concrete
- 51 Concrete Structures
- 52 Reinforcement
- 54 Waterproofing
- 61 Drainage Facilities- General
- 64 Plastic Pipe
- 65 Concrete Pipe
- 66 Corrugated Metal Pipe

68	Subsurface Drains
70	Miscellaneous Drainage Facilities
71	Existing Drainage Facilities
72	Slope Protection
73	Concrete Curbs and Sidewalks
80	Fences
96	Geosynthetics

7.2.2 Standard Special Provisions

SSPs may be included for a project that constructs a DSF. Additional SSPs may be required depending on the types of appurtenant facilities and materials proposed for the project. The listed SSP section numbers are presented to assist in preparing the Contract Special Provisions. Consult the current index of SSPs available on the Office of Construction Contract Standards section of the Caltrans website. Each SSP topic should be examined in the context of the entire project to determine if other SSPs may be required.

7.2.3 Non-Standard Special Provisions

A project that constructs a DSF may require nSSPs so the PE can assure the design assumptions are constructed properly in the drainage system. The PE and PDT should decide the most appropriate specifications for the site-specific conditions to meet other goals in the HDM for safety. OHSD can provide nSSPs to support the design. nSSPs may be required when standard specifications are insufficient to address all the design and construction needs for the project.

Below is a list of the nSSPs that may be applicable to DSFs. It is possible that not every nSSP listed below will apply to all situations or that additional nSSPs are applicable to the project. Ensure that the selected nSSPs are relevant when incorporated in the Contract Special Provisions. Other nSSPs may be necessary for the project, including for special design considerations. Coordination with OHSD or other appropriate office may be necessary.

- Filter Media
- Fiberglass baffle wall
- Aluminum Covers
- Rubber Check Valves
- Concrete Structures
- Miscellaneous Metal
- Permeable Material
- Storage Cell Media

When storage cell media is used an nSSP will be required. The storage cell media should consist of modular drainage cells manufactured of polypropylene with a minimum void ratio of 80 percent. Storage cell media that may encounter traffic loading must meet the Load and Resistance Factor Design (LRFD) criteria. All storage cell media must be installed per manufacturer requirements. The following products may be considered for use on a project specific basis: Atlantis Drainage Cell, EcoRain Drainage Cell, or VersiCell 3025. The PE may allow other manufacturers to be proposed for approval as equal.

7.3 Project Cost Estimates

Project Cost Estimates are required at every phase of the project: Project Initiation Document (PID), Project Approval/Environmental Document (PA/ED), and PS&E. The Caltrans Division of Design has developed the following website to assist in the development of cost estimates:

<http://www.dot.ca.gov/design/pjs/index.html>

This website includes links to Chapter 20 Project Development Cost Estimates of the Project Development Procedures Manual and Caltrans Cost Estimating Guidelines. In addition to Chapter 20, this website includes other useful cost estimating information on project cost escalation, contingency and supplemental work, and cost estimating templates for the planning and design phases of the project. These templates may be used to track estimates relating to costs for incorporating TBMPs.

7.3.1 PID and PA/ED Phases

A preliminary cost estimate, Project Planning Cost Estimate (PPCE), is required as an attachment of the SWDR during the PID phase of the project. A refined version of the PPCE is developed in PA/ED phase. For details on what needs to be included in PPCE, refer to Section 6.4.9 and Appendix F of the PPDG.

At the PID phase of the project, the construction cost for DSFs could be estimated based on the findings of the BMP Retrofit Pilot Program Final Report, which was \$54/CF of WQV treated.² To determine an initial cost estimate using this value simply use the following equation:

$$\text{Initial construction cost} = (\$54/\text{CF}) \times \text{WQV}$$

This estimate will need to be modified as the project progresses. If some design is conducted during the PA/ED phase of the project, it is possible that a refined estimate could be made using the methods in Section 7.3.2. A cost escalation

² In 1999 dollars; contact District Office Engineer for appropriate run-up factors based on local experience. The initial cost included with pretreatment Biofiltration Strip, but this should be considered as a minor component of the cost.

should be added for projects that are anticipated to advertise more than a year after the date of the estimate.

7.3.2 PS&E Phase

Preliminary Engineer's Cost Estimates (PECE) are initiated at the beginning of PS&E, and are updated until the completion of PS&E phase of the project. PECEs focus on the construction costs of the project and the permanent BMPs and are inputs to the Basic Engineering Estimating System (BEES). Verify the quantities for inclusion in the project cost estimate to identify which should be considered Final Pay items, and to determine appropriate unit prices for each. Develop all necessary earthwork quantities for each specific DSF location. Limits of excavation and backfill are determined by the PE and should be in accordance with the Legend, "Notes", of the DSF Detail Drawings.

7.4 Developing DSF Cost Estimates

Develop a quantity-based cost estimate, regardless of availability of specific unit cost or quantity data. As the design process proceeds, the project cost estimate should be updated as new data becomes available. Identify contract items required to construct the DSF. A challenging aspect of developing a cost estimate is determining the BMP limits of work. Only costs for work exclusively used to construct the TBMP should be included in the estimate.

Additionally, it may not be necessary to include costs for items that support the TBMP. For example, utility relocation, maintenance vehicle pullouts, traffic safety items, drainage systems, or other site design elements that are required for the project even if the TBMP was not needed. Include the costs for these items when they are exclusively required for the TBMP.

Specific data is available to assist in the preparation of the project cost estimate, and the DSF Detail Drawings provide accurate quantities for the following construction items:

- Concrete
- Bar Reinforcing Steel
- Miscellaneous Metal
- Class 4 Permeable Material
- Class 5 Permeable Material
- 6-inch Perforated Plastic Pipe Underdrain
- 6-inch Non-Perforated Plastic Pipe Underdrain
- Class D Filter Fabric
- Welded Wire Fabric
- Access Covers

When developing costs based on unit quantities, the cost estimates should be based upon the Contract Cost Data Book, and recent District 8 Cost Data Base for current similar projects.

<https://sv08data.dot.ca.gov/contractcost/>

Use the project specifications, SSPs, and nSSPs to develop a list of items for which unit costs should be supplied. Carefully check that all items of work are accounted for either as pay or non-pay items.

If the DSF is a Special Design, as defined elsewhere in this document, then quantities for cost estimating and construction pay items will need to be calculated and incorporated into the modified DSF Detail Drawings and estimates. Estimate the total cost of each DSF used on the project for tracking TBMP costs at PS&E. Document all TBMP costs in the project SWDR at PS&E.

7.5 Plan Sheet Approval

The DSF Detail Drawings may be used when standard sized vaults are incorporated. A set of pdf drawings can be requested from OHSD. At the PS&E phase, the PE must request an electronic copy of drawings that will be incorporated into the PS&E package to be submitted to the District Office Engineer. Prior to submitting the plans to DES Office Engineer, the PE is responsible to request the latest plans available to see if revisions have been made. If so, the new set of plans must be incorporated into the project.



Section 8

Special Design

The DSF Detail Drawings account for specific design load cases. A Special Design will be required where the design parameter values are beyond the ranges given in Sections 2 and 3. Conditions that do not meet the standard design criteria may include:

- High ground water table (above the bottom of the concrete footing of the DSF)
- Surcharge loads that exceed the DES Underground Structures design criteria (LRDF)
- Inadequate bearing capacity
- Freeze-thaw or corrosive conditions
- Excessive or uneven settlement due to seismic or other causes

This section provides guidance for situations where the specific project requirements do not meet the design parameters specified in the DSF Detail Drawings. The following recommendations are provided as alternatives to expand the applicability of the DSFs beyond the design elements and constraints shown in the DSF Detail Drawings.

Note that any of the following design approaches may require additional engineering, such as a structural and hydraulic analysis, or ground modification. Consult with OHSD when considering special designs.

8.1 Alternative Filter Media

If alternative filter bed media, such as sand and peat, is being proposed, consult with DEA and OHSD for approval or to determine if a Special Design or pilot is required.

8.2 Alternative BMP Sizing

The DSF sizing calculations in this guidance are intended for standard inline designs under normal conditions with typical external loading requirements and have prescriptive configurations. Alternative calculations may be generated by the PE for a specific project to refine the BMP size. One alternative may be to use the California Stormwater Quality Association (CASQA) TC-40 methodology (CASQA 2003). The TC-40 includes the following rule-of-thumb for sizing the filter area (A_{fc}):



If the filter is preceded by a sedimentation basin that releases the WQV to the filter over 24-hours, then the minimum average surface area for the sand filter is:

$$A_{fc} = WQV/18$$

If no pretreatment is provided, then the minimum average surface area for the sand filter is:

$$A_{fc} = WQV/10$$

Additionally, the calculations in this guidance assume instantaneous runoff to the BMP (i.e., 'slug-flow') which does not consider active treatment during the event, leading to conservative sizing designs. A sizing alternative to account for timing of runoff is to perform rainfall-runoff and unsteady-flow storage routing computations for the BMP. When the runoff is distributed over the duration of an event, early-event runoff can be treated and released before the peak runoff arrives. Using these calculations, the BMP does not need to be sized to store the entire runoff volume at once (i.e., 'slug-flow'), leading to smaller designs. By accounting for active treatment occurring during the event, an increase in the treated WQV listed in Table 3-1 of up to 50 percent can be expected.

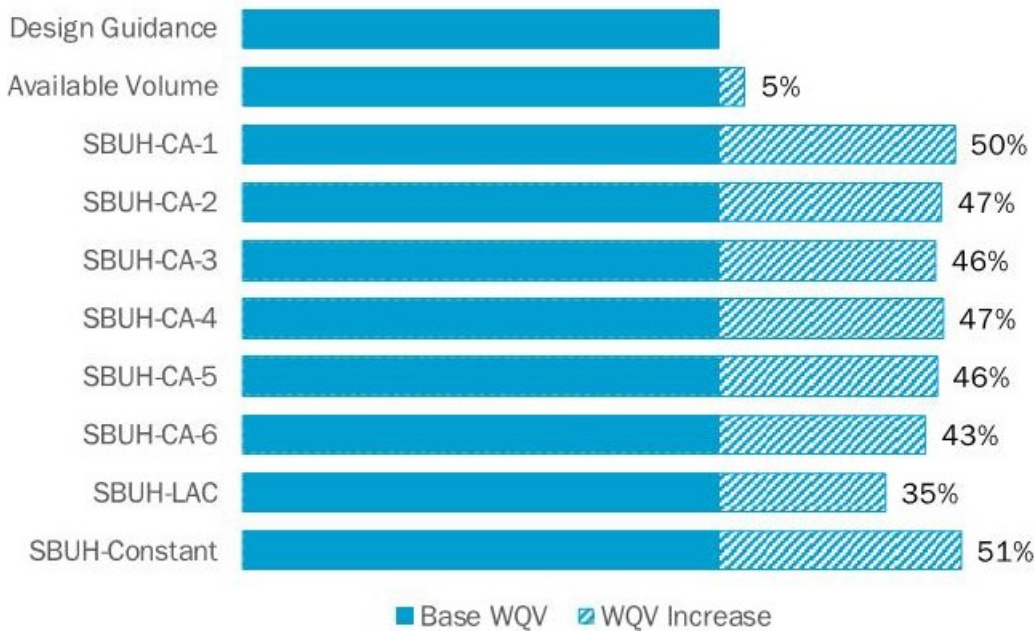

Figure 8-1. Example of Maximum WQV Treated in a Media Filter

Figure 8-1 shows an example calculation comparing treated WQV using the 'slug flow' method vs the hydrograph routing method in an AVSF. The base WQV shown in Figure 8-1 is the WQV treated as calculated using the slug-flow method. The WQV increase is the additional WQV treated by the same size BMP using an unsteady-

flow routing method and select rainfall distributions. While these AVSF findings are generally applicable to all media filters, both the percolation rate and the area of the filter relative to the total storage volume will impact treatment capacity. Project specific sizing calculations are required to ensure the WQV is treated without overtopping the facility. Details of this methodology and findings are discussed in the Review of Design Guidance for Sizing Media Filters for Stormwater Quality Treatment (Caltrans 2019e).

Alternative calculations may be used by the PE for a specific project and must be developed by a qualified professional in consultation with the District/Regional Design Stormwater Coordinator and documented in the SWDR. Consult with DEA and OHSD for design approval or to determine if a Special Design or pilot is required.

8.3 Oversized Inlet Pipe

The existing storm drain pipe may have been oversized (i.e. greater than 2.83 ft); if this is the case, a reducer may be utilized to meet the required diameter for the DSF inlet pipe. Consult with District Hydraulics for concurrence.

8.4 Greater Wall Height

If the estimated wall height is identified to be greater than the designed wall heights in Table 3-1, a special wall design is needed. Coordinate with Structure Design to design the required wall height for the device.

8.5 Site Limitations

Limited Head Drop: In the event the hydraulic head drop at the site is less than the required head drop for the device, follow the procedure presented in Section 3.2 to calculate the size of the device. Depending on the calculated size of the device, PE can still select a DSF Model from Table 3-1, with lower wall height. The PE should consult with OHSD.

Shape of DSF: If site conditions do not allow a DSF of rectangular shape, PE should follow the procedure in Section 3.2, and develop alternative configurations.

Environmental Conditions: Special design is also required for the groundwater conditions above the bottom of the DSF, surcharge loads exceeding DES Underground Structures design criteria for truck loads, snow load, design bearing pressures, and for freeze thaw conditions.

8.6 Customizing the DSF Detail Drawings

When using a Special Design, the DSF Detail Drawings must be modified as required to show any changes relative to the following:

- **Design WQV Tables:** If different WQVs or DSF dimensions are used, these new values are to be reflected in the Design WQV Table on the Legend of the DSF Detail Drawings. This is to be noted as Non-Standard data under the “Design Notes” section on the Legend of the DSF Detail Drawings.
- **Legend – “General Notes” Section:** Any notes should be changed as required to fit the Special Design.
- **Reinforcing Steel Tables:** The Reinforcing Steel Tables on the Footing Details, Interior Wall Details, and Exterior Wall Details of the DSF Detail Drawings should be updated for new dimensions.
- **Quantity Summary Tables:** The Miscellaneous Item Quantities table should be updated for new values.
- **Dimensions:** In general, changing the design of the DSF structures may result in changes to various dimensions. These should be updated on all sheets, views, sections, and details.

Additional changes may be required to facilitate use of the DSF Detail Drawings. A structural review is required whenever there are changes in geometry not covered on the drawings. The changed drawings must go through the standard PS&E review process and then be signed and sealed by the PE that completed the approved structural calculations.

Section 9

Design Example

9.1 DSF Selection Example

This section presents an example on how to implement the DSF design procedure presented in Section 4 at a specific site. This example site is in the City of Murrieta at the I-215 and Clinton Keith Road interchange in District 8 (Figure 9-1). The layout of the proposed DSF structure is shown in Figure 9-2.

The hydraulic procedures used in this example are site-specific. Therefore, hydraulic engineer should determine the site-specific conditions that may require modifications or alternative procedures in the design at other locations.

Step 1: Review Site Conditions

The Design Storm flow (Q_d) for the site is 9.37 cfs based on the 100 year storm event [peak design flow can be for a shorter storm event, i.e 25-year or 10-year depending on the local design criteria]

The area available to place the DSF device is approximately 130 ft by 50 ft in the northwest quadrant of the interchange.

- Inlet piping to the DSF would be a new installation from the upstream catch basin.
- The FG elevations at the site in the vicinity corresponding to the inlet-side corners of the DSF are 1,510 ft and 1,511.25 ft, and FG elevations at the outlet-side corners of the DSF are 1,510 ft and 1,511 ft (Figure 9-1).
- The FG elevation at the closest upstream catch basin is approximately 1,516 ft.
- The WQV of 14,320 CF is obtained from the project SWDR.
- The flow line elevation of the downstream 66-inch pipe (Figure 9-3), where the DSF outlet would be connected is at about 1,494 ft. Therefore, the elevation difference available from the FG at the DSF location to the outlet connection point is about 18 ft, which is adequate for installing a DSF.
- During the Design Storm event, pressure flow conditions would occur in the 66-inch pipe, and the hydraulic grade line (HGL, head) would be at about 1,500 ft elevation at the site.

Step 2: Select DSF Type and Configuration

For the WQV of 14,320 CF, select a short configuration DSF type 'S-15000' for this site from Table 3-1. DSF type 'S-15000' is chosen over DSF type 'L-15000' due to a smaller footprint that can fit in the available area. Consider DSF Subtype 2 for this site. A

weir overflow requires less head than required for a pipe overflow structure (Subtype 1). Less head results in shorter wall heights and a shallower device.

Obtain the following dimensions from Table 3-1 for DSF type S-15000:

- W: 15 ft
- $L_s = L_f$: 110 ft
- H_w : 5 ft
- d_f : 1.5 ft
- $d_{g-u/s}$: 1 ft
- $d_{g-d/s}$: 2.1 ft
- h_d : 4.25 ft

Calculate the following design parameters:

- h_o : At Q_d of 9.37 cfs, 0.34 ft of head (h_o) is needed for a weir overflow as calculated from sharp crested weir formula as follows (refer to Section 3.2.5 for formula description):
 - $Q_d = 3.33Lh_o^{3/2}$
 - Therefore, $h_o = (9.37 \text{ cfs} / (3.33 \times 15 \text{ ft}))^{2/3} = 0.34 \text{ ft}$
- h_f : use freeboard of 1.0 ft
- h_{fo} : Elevation drop between sedimentation or filter chamber footing slab and overflow chamber slab (h_{fo}) is 0.33 ft (Refer to Footing Details of DSF Detail Drawings)
- DSF Inlet pipe diameter: For Q_d of 9.37 cfs, the inlet pipe diameter is estimated as 2 ft using outlet control culvert hydraulic nomograph for a less than 0.4 ft headwater depth (FHWA 2001). To be conservative, a 2.25-ft diameter inlet pipe is used.
- DSF Outlet pipe invert: As mentioned in Step 1, the HGL during the Design Storm event for the 66-inch diameter pipe is about 1500 ft, therefore, set the DSF outlet invert elevation at 1499.5 ft. This would cause the overflow chamber to be flooded up to ± 0.5 ft depth, which would have minimal impacts on the DSF.
- DSF Inlet pipe invert: The DSF inlet invert elevation is determined as follows:
Inlet pipe invert = Outlet pipe invert + $h_d = 1,499.5 \text{ ft} + 4.25 \text{ ft} = 1,503.75 \text{ ft}$
- Design Water Surface Elevation (DWSE): DWSE within the DSF device is calculated as follows (Refer to Details No. 1 of DSF Detail Drawings):
 - $DWSE = \text{DSF outlet invert elevation} + h_{fo} + d_{g-d/s} + d_f + H_w + h_o$
 - $DWSE = 1,499.5 \text{ ft} + 0.34 \text{ ft} + 2.1 \text{ ft} + 1.5 \text{ ft} + 5 \text{ ft} + 0.34 \text{ ft} = 1,508.77 \text{ ft}$
 - The FG elevation at the planned DSF device is in the range of 1,510 ft to 1,511 ft. With DWSE of 1,508.77 ft, sufficient freeboard (greater than 1 ft) is available in the DSF (Figure 9-2).

- Backwater conditions in the upstream catch basin: For a 2.25 ft diameter inlet pipe, the head needed for flow from the upstream catch basin to the DSF device is estimated as less than 0.4 ft from outlet control culvert hydraulic nomograph (FHWA 2001, Chart 5B).
- By using 0.4 ft of head, the upstream catch basin invert can be set at elevation 1,509.2 ft, i.e. DWSE (1,508.77 ft) + (0.4 ft). The FG elevation around the upstream catch basin is $\pm 1,516$ ft (Figure 9-3), therefore the invert elevation of 1,509.2 ft would provide adequate freeboard in the upstream catch basin during the 25-year storm event. If needed, the upstream catch basin can be allowed to flood.

Step 3: Determine DSF Wall Heights, And Total Length, Width and Depth

Refer to Figure 4-2 for procedure of determining wall heights. In addition, refer to Layout No. 1 and Layout No. 2 of the DSF Detail Drawings for dimensions of the DSF.

- FG elevations: Finished grade elevations corresponding to the inlet-side corners of the DSF are 1,510 ft and 1,511.25 ft, and FG elevations at the outlet-side corners of the DSF are 1,510 ft and 1,511 ft, (Figure 9-1).
- Top of Wall elevations: Establish the top of the wall elevations at the four corners, (WE1, WE2, WE3, and WE4), at 0.5 ft of stick-up height (h_s) above their corresponding FG elevations, (1,510 ft to 1,511 ft). Establish the top of the wall elevations at all four corners of the DSF as 1,511.5 ft for a uniform wall height, (Figure 9-4).
- Footing elevations: Determine the footing elevations, (FE1, FE2, and FE3), at the four corners of the DSF, (refer to Layout No. 1 of the DSF Detail Drawings). The footing elevations, (FE1, FE2, and FE3), are obtained as follows, (refer to Figures 9-2 and Figure 9-4):
 - $FE\ 1 = DWSE - (h_o + H_w + d_f + d_{g-u/s}) = 1,508.77 - (0.34 + 5 + 1.5 + 1) = 1,500.93$ ft
 - $FE\ 2 = DWSE - (h_o + H_w + d_f + d_{g-d/s}) = 1,508.77 - (0.34 + 5 + 1.5 + 2.1) = 1,499.83$ ft
 - $FE\ 3 = FE2 - h_{fo} = 1,499.83 - 0.34 = 1,499.49$ ft
- Wall heights: Calculate wall heights at all four corners of the DSF as follows:
 - Design wall height (H) = wall elevation (WE) – footing elevation (FE)
 - $H1 = WE1 - FE1 = 1,511.5 - 1,500.93 = 10.57$ ft
 - $H2 = WE2 - FE3 = 1,511.5 - 1,499.49 = 12.01$ ft
 - $H3 = WE3 - FE3 = 1,511.5 - 1,499.49 = 12.01$ ft
 - $H4 = WE4 - FE1 = 1,511.5 - 1,500.93 = 10.57$ ft
- Total DSF Depth: Calculate the total depth of the filter (D) as follows:
 - $D = H + d_{ff}$
 - d_{ff} is 1.75 ft for Design Wall Height (H) up to 14 ft. Refer to Footing Details of the DSF Detail Drawings
 - $D1 = 10.57 + 1.75 = 12.32$ ft; say 13 ft $D3 = 12.01 + 1.75 = 13.76$ ft; say 14 ft

- $D2 = 12.01 + 1.75 = 13.76$ ft; say 14 ft $D4 = 10.57 + 1.75 = 12.32$ ft; say 13 ft
- Total Length and Width:
 - Select the L_T and W_T based on $H = 14$ ft
 - $L_T = 120.67$ ft
 - $W_T = 36.33$ ft

Step 4: Check DSF Footprint

Calculate the exterior concrete dimensions of the DSF. The L_T of 120 ft and W_T of 35.83 ft for design H up to 12 ft are determined from Table 3-1 for DSF S-15000. Available footprint area, (130 ft by 50 ft), for a DSF at the site is enough to install DSF type 'S-15000'.

9.2 PS&E Preparation

Incorporate the DSF design into the PS&E package, including revising the required drawings and adding the necessary DSF Detail Drawings. For the example above, the following drawings are to be revised as shown:

- **Layout:** Show location of the selected DSF configuration 'S-15000'.
- **Drainage Plan:** Show the selected DSF plan with the existing and proposed drainage conveyance system, including pipes and inlets.
- **Drainage Profile:** Show the selected DSF profile with the existing and proposed drainage conveyance system, including pipes and inlets.

9.3 Alternative Design Considerations

The DSF design at a site is controlled by the space and the hydraulic head available between the upstream and downstream drainage system of the BMP. The DSF can be designed as indicated below for different site conditions compared to those noted above.

- **Downstream Design Water Surface Elevation is Higher:** Large footprint area DSF (L-15000) should be selected with lesser H_w requirements, and DSF outlet elevation can be raised. Additionally, the upstream drainage system can be allowed to flood if minimum freeboard requirements are achievable without upstream back flooding. A flap gate can be applied at the DSF outlet to prevent back flooding of the DSF if the BMP cannot be raised above certain elevations depending on site conditions.
- **Downstream Design Water Surface Elevation is Lower:** If the design water surface elevation is lower, the outlet pipe can be designed at a steep slope, or a drop structure can be provided downstream, and the DSF outlet elevation should not be lowered.

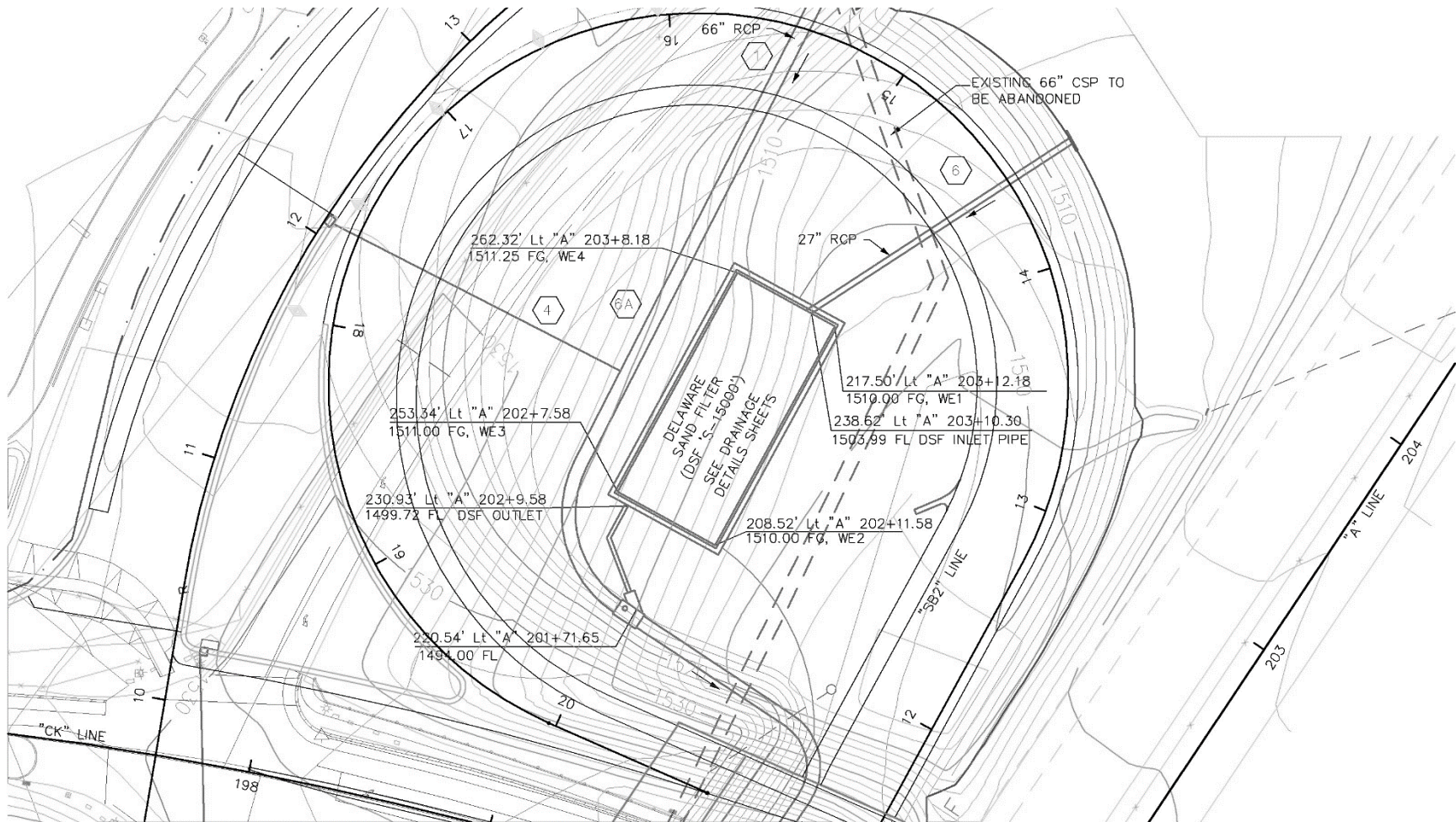

Figure 9-1. DSF Location

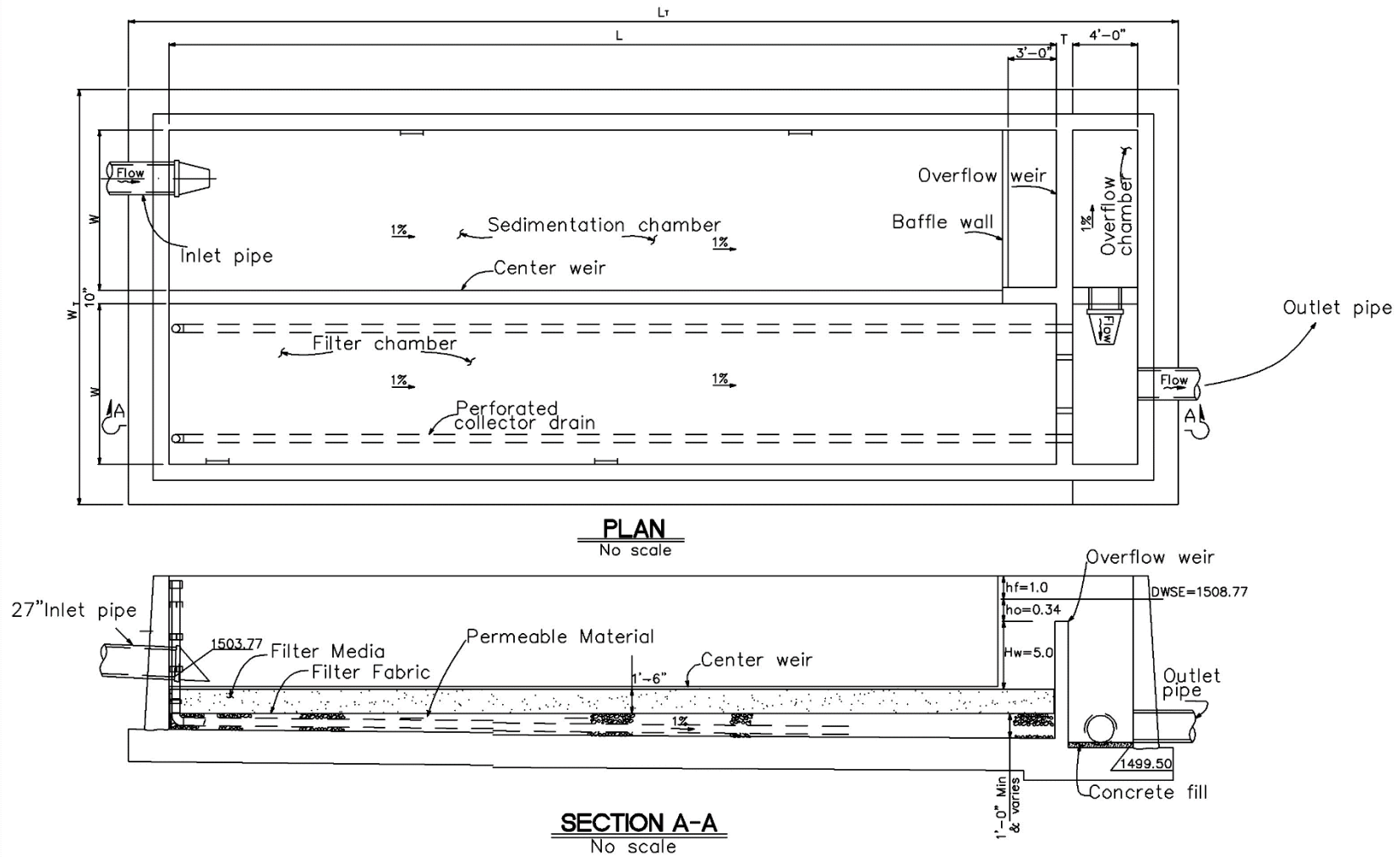

Figure 9-2. DSF Layout



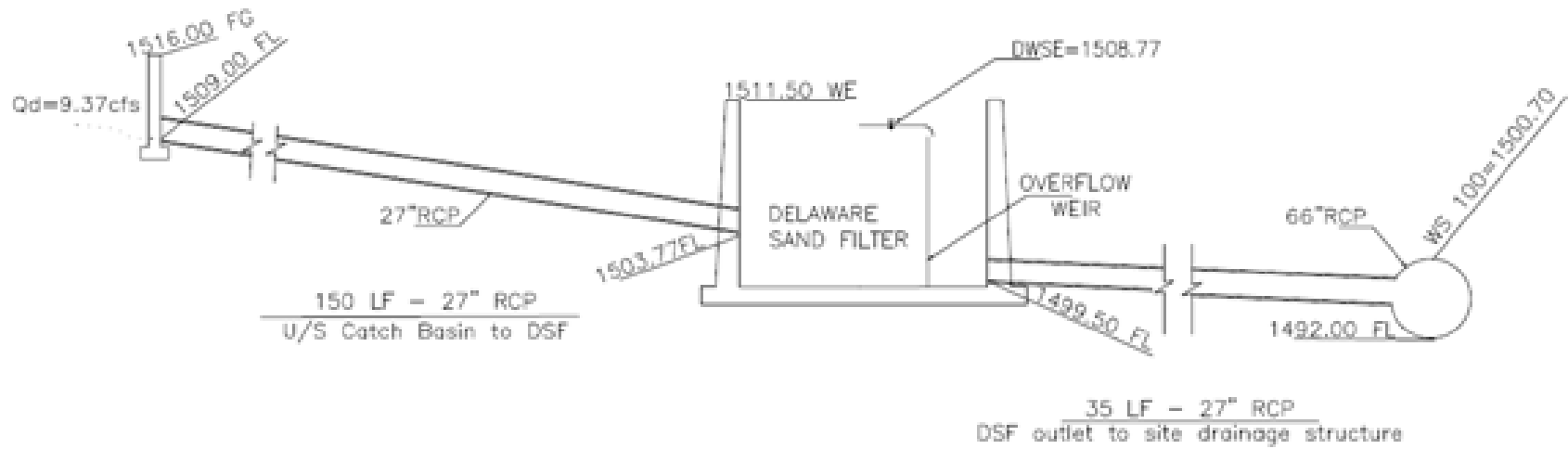

Figure 9-3. System Profile

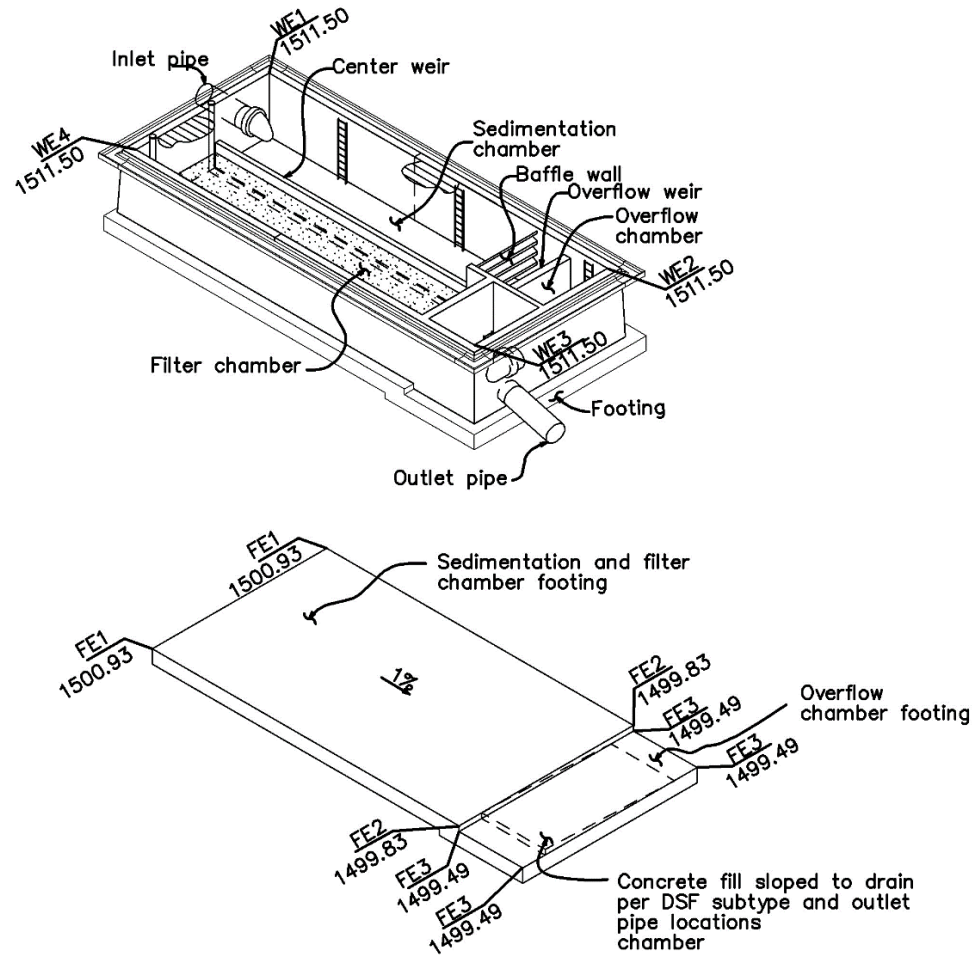

Figure 9-4. DSF Wall and Footing Elevations



Section 10

References

- American Association of State Highway and Transportation Officials (AASHTO), 2011. Roadside Design Guide; with errata published in 2015
- California Department of Transportation (Caltrans), 2020a. Highway Design Manual 6th Edition, March 2020
- California Department of Transportation (Caltrans), 2020b. Caltrans Delaware Sand Filter Detail Drawings, 158DSFPlans.zip, available upon request from OHSD, Accessed June 2020.
- California Department of Transportation (Caltrans), 2020c. Stormwater Quality Handbooks: Supplemental Details Design Guidance
- California Department of Transportation (Caltrans), 2020d. Stormwater Quality Handbooks: Flow Splitters Design Guidance
- California Department of Transportation (Caltrans), 2019a. Stormwater Quality Handbooks: Design Pollution Prevention Infiltration Area Design Guidance, April 2019
- California Department of Transportation (Caltrans), 2019b. Stormwater Quality Handbooks: PPDG (PPDG), April 2019
- California Department of Transportation (Caltrans), 2019c. Statewide Trash Implementation Plan, April 2019
- California Department of Transportation (Caltrans), 2019d. Construction Contract Development Guide, Version 5.0, July 2019
- California Department of Transportation (Caltrans), 2019e. Review of Design Guidance for Sizing Media Filters for Stormwater Quality Treatment, CTSW-TM-16-314.17.1, January 24, 2017, Revised September 17, 2019
- California Department of Transportation (Caltrans), 2018. Multi Benefit Treatment BMP Trash Full Capture Requirements – Design Guidance, October 2018
- California Department of Transportation (Caltrans), 2004. BMP Retrofit Pilot Program Final Report, CTSW-RT-01-050, January 2004
- California State Water Resources Control Board ORDER 2012-0011-DWQ, NPDES NO. CAS000003 for State of California Department of Transportation Statewide Storm Water Permit, referred to as "NPDES Permit"
- Federal Highway Administration (FHWA), 2009. Hydraulic Engineering Circular (HEC) No. 22, 3rd Edition, Urban Drainage Design, September 2009; revised August 2013
- Federal Highway Administration (FHWA), 2001. Hydraulic Design Series (HDS) No. 5: Hydraulic Design of Highway Culverts, September 2001

This page intentionally left blank.

