

DIST.	COUNTY	ROUTE	POST MILES TOTAL PROJECT	SHEET No.	TOTAL SHEETS
REGISTERED CIVIL ENGINEER			DATE		
PLANS APPROVAL DATE					
<small>The State of California or its officers or agents shall not be responsible for the accuracy or completeness of scanned copies of this plan sheet.</small>					
<small>The Registered Civil Engineer for the project is responsible for the selection and proper application of the component design and any modifications shown.</small>					

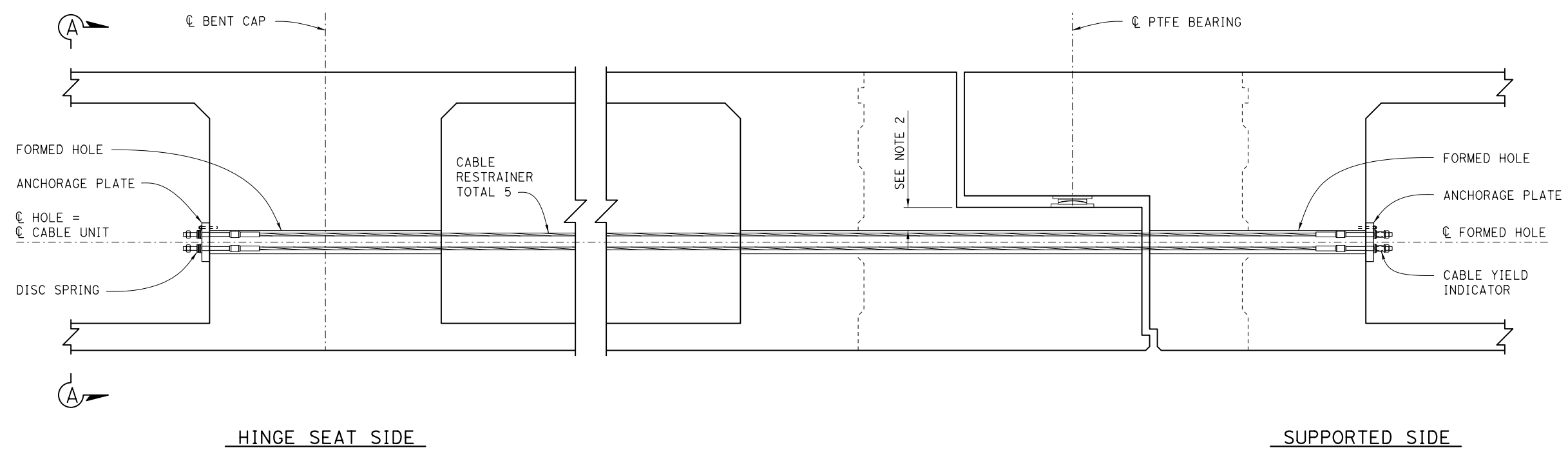

RESTRAINERS IN NEW CONSTRUCTION
 $\frac{3}{4}'' = 1'-0''$

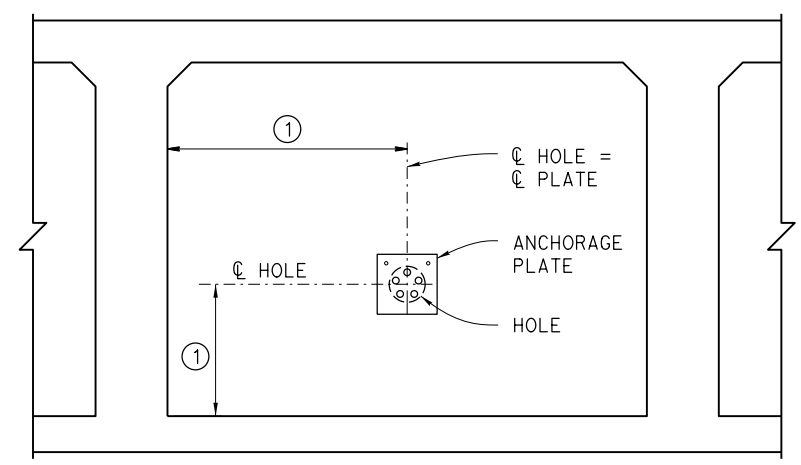

VIEW A-A
 $\frac{3}{4}'' = 1'-0''$

① For Location of hole, see Structure Plans.

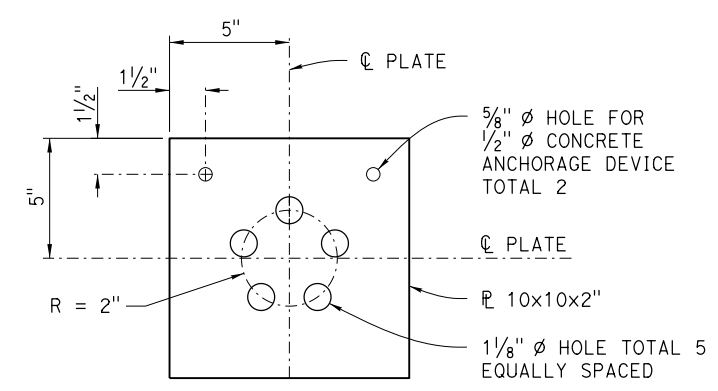

ANCHORAGE PLATE
 $3'' = 1'-0''$

Notes

1. The Formed Hole must be 6" ϕ and must be aligned to form a straight line the entire length of the restrainers and be parallel to the ϕ girder. The Hole must be formed with the Top of Hole 2" below the seat's top main reinf. During construction hole ends must be capped to prevent debris intrusion.
2. The Bearing surface must be perpendicular to girders.
3. For Cable Restrainer and Hardware details see: XS7-090, "Cable Restrainer Hardware Details" sheet.
4. Reinforcement not shown.

BRIDGE STANDARD DETAILS		NOTES TO DESIGNER Remove these notes at PS&E Place Restrainers between bearings.	STATE OF CALIFORNIA	DIVISION OF ENGINEERING SERVICES	BRIDGE NO.		
xs7-040 <small>FILE NO.</small>	July 2014 <small>APPROVAL DATE</small>		<small>The components of the Bridge Standard Details have been prepared under the responsible charge of the Technical Owner, a registered civil engineer in the State of California.</small>	DEPARTMENT OF TRANSPORTATION	CABLE RESTRAINER TYPE 1 (NEW)	POST MILE	
<small>Refer to: http://www.dot.ca.gov/hq/esc/techpubs/manual/bridgemanuals/bridge-standard-detail-sheets/index.html</small>		<small>FILE => xs7-040.dgn</small> <small>USERNAME => s136236</small>	<small>TIME PLOTTED => 07:27</small> <small>DATE PLOTTED => 12-JUL-2016</small>	<small>ORIGINAL SCALE IN INCHES FOR REDUCED PLANS</small> 0 1 2 3	<small>UNIT: PROJECT NUMBER & PHASE:</small> <small>CONTRACT NO.:</small>	<small>DISREGARD PRINTS BEARING EARLIER REVISION DATES</small> REVISION DATES: 4-14-14 7-8-16	SHEET OF