

**DEPARTMENT OF TRANSPORTATION**  
**DIVISION OF ENGINEERING SERVICES**  
Transportation Laboratory  
5900 Folsom Blvd.  
Sacramento, California 95819-4612



## **METHOD OF TEST FOR RELATIVE COMPACTION OF UNTREATED AND TREATED SOILS AND AGGREGATES**

### **A. SCOPE**

This test method describes the procedure used to determine the relative compaction of untreated and treated soils and aggregates.

Relative compaction in this method is defined as the ratio of the in-place, wet density of a soil or aggregate to the test maximum wet density of the same soil or aggregate when compacted by a specific test method.

The procedures are presented in 2 parts:

- Part 1. Determine the in-place, wet density
- Part 2. Determine the laboratory test maximum wet density and percent relative compaction

### **B. REFERENCES**

- California Test 110 – Calibration of Compaction Test Equipment
- California Test 226 – Moisture Content of Soils and Aggregates by Oven Drying
- California Test 231 – Relative Compaction of Untreated and Treated Soils and Aggregates Using Nuclear Gauges
- California Test 312 – Designing and Testing Classes "A" and "B" Cement Treated Bases
- AASHTO T 191 – Density of Soil In-Place by the Sand-Cone Method
- ASTM D 1556 – Density and Unit Weight of Soil in Place by Sand-Cone Method

## **PART 1. IN-PLACE, WET DENSITY**

### **1A. SCOPE**

The principal use of the in-place, wet density value is in the relative compaction control of earthwork construction. However, the identical procedure and apparatus are also employed to obtain data for volume-to-weight conversion factors and shrinkage or swell factors.

### **1B. TEST PROCEDURE**

The determination of the in-place wet density requires excavating and weighing a sample of soil from the area under investigation, measuring the volume of the sample excavation by back-filling with calibrated test sand, and calculating the unit wet weight of the excavated sample.

Perform this test in accordance with AASHTO T 191.

NOTE: Typically, the test hole excavation alone will not provide a sufficient volume of material required for completion of Part 2 of this test method. Therefore, it is necessary to obtain a bulk sample of soil immediately adjacent to the excavated test hole following the completion of the sand volume measurement.

## 1C. REPORTING OF RESULTS

The block headed "Sand Volume Data" on the Relative Compaction Test Worksheet (Form TL-297 attached) provides for the data accumulated at the in-place test hole site.

## PART 2. LABORATORY COMPACTED TEST MAXIMUM WET DENSITY AND PERCENT RELATIVE COMPACTION

### 2A. APPARATUS

1. The standard California impact compaction test apparatus consisting of a split cylindrical mold, a 10.0 lb tamper, a metal piston, and a piston-handling rod, as illustrated in Figure 1. (See California Test 110 for calibration.)
2. A concrete base block, or an equally rigid body, approximately 1 cu ft in size.
3. Balance: a balance or scale of at least 3 kg capacity and sensitive to 1 g.

### 2B. TEST PROCEDURE

A bulk sample of soil is divided into smaller portions. These portions are prepared with varying moisture contents to form test specimens, which are individually compacted by a uniform compactive effort, to determine the test maximum density for the particular soil under consideration.

NOTE: The test maximum density determination and percent relative compaction for Class A Cement Treated Base (CTB) is determined in accordance with California Test 312.

### 2C. BULK SAMPLE

Obtain a bulk sample of soil, 35 lb minimum in weight, at the site of the in-place density test hole. It is essential that the bulk sample be preserved at the same moisture as prevailed at the time of excavation for the duration of the test. Use only moisture-proof containers and protect from high temperatures.

### 2D. PREPARATION OF TEST SPECIMENS

1. Separate the bulk sample on the  $\frac{3}{4}$  in. sieve, weigh both the retained and passing fractions, and compute the percentage retained in terms of wet weight of the total bulk sample. If 10 % or more of the total weight is retained on  $\frac{3}{4}$  in. sieve, follow the test procedure set forth in Section 2I. If the retained  $\frac{3}{4}$  in. fraction comprises less than 10 % by weight of the total bulk sample, discard it and divide the passing  $\frac{3}{4}$  in. fraction into representative 5 test specimens of equal weight (within  $\pm 1$  g), each sufficient in amount to form a compacted test specimen of 10 to 12 in. in height when compacted as specified in Section 2E.

NOTE: Sufficient samples should be prepared to satisfy the conditions of 2E.5.a. While these conditions are often met with 3 samples, it is prudent to separate 5 samples at this stage.

2. It is of the utmost importance that all of the bulk sample material be thoroughly mixed. Each test specimen must be representative of the soil or aggregate mass, be of equal weight, be weighed in immediate succession, and be placed at once in the 1 gal moisture-sealed individual containers.

3. The correct weight for each test specimen will depend on the soil type and the moisture content. 2200 to 2700 grams wet weight is the usual range of weight.
4. Record the initial weight of the individual test specimens on Line I of Form TL-297.

## 2E. COMPACTION OF TEST SPECIMENS

1. Divide 1 of the test specimens prepared as outlined in Section 2D into 5 approximately equal portions by either weight or volume measurement and store in separate ¼ gal moisture-sealed containers. Place 1 portion in the test mold and compact it with 20 blows of the tamper dropping free from a height of 18 in. above the surface of the material in the mold. Repeat this operation for each of the remaining 4 portions. After the compaction of the fifth portion, place the piston in the mold and level the top of the compacted specimen with 5 blows of the tamper dropping free from a height of 18 inches above the surface of the piston.
2. With the tamper foot resting on the piston atop the compacted test specimen, read the graduated tamper shaft to the nearest graduation at a point level with the top of the mold. Enter this value on Line J of Form TL-297.

NOTE: If a graduation is not level with the top of the mold, read the next highest graduation – i.e., the first graduation just below the top of the mold.

3. Obtain the adjusted wet density in grams per cubic centimeter from Table 1 corresponding to the tamper shaft graduation reading using the column corresponding to the initial wet weight of test specimen (Line I) and record it on line K of Form TL-297.
4. Save the specimen temporarily for possible later use. (See the first paragraph of Section 2G.)
5. Adjust the moisture contents of the remaining test specimens to satisfy the following conditions:
  - a. The object is to have at least 1 test specimen with moisture content below test optimum, 1 close to optimum and 1 above optimum, at about 2 % moisture content increments, with a minimum of 3 test specimens. While the actual moisture contents will not be known, the moisture content of the test specimen with the highest adjusted wet density is the test optimum moisture content even though the moisture content is unknown. Therefore, the primary objective is to have a number of test specimens and a range of moisture contents such that at least 1 specimen will be compacted at a moisture content less than, and 1 at a moisture content greater than, the moisture content of the specimen having the highest adjusted wet density. If this condition cannot be satisfied with the minimum 3 test specimens it will be necessary to fabricate additional specimens.

NOTE: With some material, aggregate base for example, it may be necessary to increase or decrease moisture increments. Once the initial increment has been determined (e.g., 1 %, 1.5 %, 2 %), it should be constant throughout the test.

NOTE: The first test specimen is generally compacted at the moisture content present in the bulk sample. If this specimen appears to be considerably drier than the optimum, mix additional water into each of the remaining specimens. If it appears to be definitely wetter than the optimum, reduce the moisture content of the other specimens by aeration. Partial oven drying may be used, but do not completely oven-dry the specimens and then remix with water. If it appears to be close to the optimum, increase the moisture content of 1 of the remaining test specimens and reduce it in the other one to bracket the initial specimen thought to be at optimum.

- c. The test optimum moisture content will usually be the minimum moisture content which will ball the soil readily when compressed into a roll by the grip of the hand, but still permit the roll to be broken without crumbling or pulverizing appreciably at the breaking point.
- d. The base plate of the test mold normally shows indications of dampness when a soil is compacted at the test optimum moisture content. Free water on the base plate definitely denotes excessive moisture content. A dry, dusty base plate signifies a deficiency of water.

NOTE: Excessive moisture on the base plate denotes a failed test point and will require that the increments of added moisture must be reduced. Additional samples must be prepared at the smaller increments to insure that the optimum moisture point is bracketed.

- 6. After adjustment of the moisture content, compact each of the remaining test specimens in the mold, then record the water adjustment, tamper reading and the corresponding adjusted wet density from the chart on Table 1 using the column corresponding to the initial wet weight (Line I of Form TL-297).
- 7. Regardless of the soil type or particle sizes involved, fresh soil (not soil from previously compacted specimens) must be used in the compaction of each test specimen. The compactive effort being equal for each layer, it is also important that the thickness of layers be equal to assure uniformity of compaction between test specimens.
- 8. Throughout the compacting operation the test mold must stand either on the standard concrete base block or on an equally rigid body.
- 9. In reassembling the test mold after removing a core, the wing nut should be drawn up only finger tight. The purpose of the wrench is to release the wing nuts when locked by expansive soils in the mold. Excessive tightening of the nuts distorts the circular cross-section of the mold. In gauging the 18-inch height of fall for the tamper, the hook and rod arrangement, shown in Figure 1, should be used.

## 2F. COMPUTATION OF RELATIVE COMPACTION

Compute relative compaction as: 
$$\text{Relative Compaction} = \frac{D_1}{D_2} \times 100$$

Where:  $D_1$  = In-place wet density as shown on Line H of Form TL-297  
 $D_2$  = Highest adjusted wet density as determined by this method

Relative compaction is expressed as percent to the nearest whole number

Note: If the computed value ends in a number with a fractional portion of 0.5 % or greater, report the relative compaction as the next higher whole number. If the computed value ends in a number with a fractional portion of less than 0.5 %, report it without changing the whole number. Figure 3 presents an example of a properly completed Relative Compaction Test Worksheet.

## 2G. MOISTURE CONTENTS

The moisture content of the specimen with the highest adjusted wet density is the optimum moisture. The moisture content of the specimen compacted without addition or reduction of water will represent the in-place moisture content of the soil at the test site. If either moisture content is desired, the determination is made in accordance with California Test 226. Once the moisture contents are determined, percent relative compaction can also be determined by relating dry in-place density to dry test maximum density.

Provision is made at the bottom of the Relative Compaction Test Worksheet (Form TL-297) for determination of the Moisture Adjustment for Aggregate Base Pay Quantities, if desired.

## 2H. MOISTURE-DENSITY CURVE

A moisture-density curve may be formed by plotting the adjusted wet density versus change in grams of water added or subtracted in adjusting the moisture contents of the test specimens. The sample curve appearing on Figure 3 was plotted from the data presented on Line K and the "Water Adjustment" line.

The highest point on the curve represents the maximum density, 2.15 in the example, at 0 grams of water ("0 grams" thus means in-place moisture content at test site is optimum moisture).

Indicate the corrected density on the plot as a dot with a circle labeled "Adjusted Density."

## 2I. CORRECTION FOR OVERSIZE MATERIAL

1. The diameter of the test mold limits the size of particles that may be included in the test to that passing  $\frac{3}{4}$  in. sieve. In those instances where the original material from which the test specimens are obtained contains 10 % or more by weight of particles retained on the  $\frac{3}{4}$  in. sieve, a correction must be applied to the test.

The density correction is calculated as follows:

$$\text{Corrected Density} = \frac{100}{\frac{\% \text{ passing } \frac{3}{4} \text{ in. sieve}}{G_1} + \frac{\% \text{ retained on } \frac{3}{4} \text{ in. sieve}}{YG_2}}$$

Where:  $G_1$  = Specific gravity of material passing  $\frac{3}{4}$  in. sieve  
 $G_2$  = Specific gravity of material retained on  $\frac{3}{4}$  in. sieve  
 $Y$  = Coefficient for  $\frac{3}{4}$  in. aggregate – see following table

Percent Retained on ¾ in. Sieve	Y
20 or less	1.00
21-25	0.99
26-30	0.98
31-35	0.97
36-40	0.96
41-45	0.95
46-50	0.94

2. Record the total weight of bulk sample on Line L of Form TL-297.
3. Separate the bulk sample on the ¾ in. sieve, wash the material retained on the ¾ in. sieve, remove excess surface water by rolling sample in a large, absorbent cloth. Weigh in air and record on Line M of Form TL-297.
4. Weigh the retained on ¾ in. fraction in water and record on Line N of Form TL-297.
5. The impact test is performed on the passing ¾-inch fraction as outlined in Sections 2C through 2E.
6. The remainder of the calculations necessary to compensate for the retained ¾-in. material and to determine percent relative compaction is shown on Lines O through V of Form TL-297.
7. When a number of tests on soil containing essentially the same nature of retained ¾ in. material are anticipated, a constant may be developed to minimize the weighing in air and water operations.

## 2J. SIMPLIFICATIONS FOR CONSTRUCTION CONTROL

Construction control by wet density tests may be expedited. If the relative compaction based on any test specimen density is below the specified minimum it may be immediately reported that the area under test has failed to meet the specifications. It is not necessary to fabricate additional test specimens for the reason that if a higher wet density was reached with subsequent test specimens the relative compaction based on this higher density would be still lower than that indicated by the single specimen. When the relative compaction indicated by a single test specimen is more than the minimum specified, additional specimens are necessary to be certain that any increase in wet test maximum density attained with the subsequent specimens does not lower the relative compaction value to below the specification minimum.

## C. HEALTH AND SAFETY

It is the responsibility of the user of this test method to establish appropriate safety and health practices and determine the applicability of regulatory limitations prior to use. Prior to handling, testing or disposing of any materials, testers must be knowledgeable about safe laboratory practices, hazards and exposure, chemical procurement and storage, and personal protective apparel and equipment.

Caltrans Laboratory Safety Manual is available at:

[http://www.dot.ca.gov/hq/esc/ctms/pdf/lab\\_safety\\_manual.pdf](http://www.dot.ca.gov/hq/esc/ctms/pdf/lab_safety_manual.pdf)

**End of Text  
(California Test 216 contains 10 pages)**

**TABLE 1**

California Impact Test Apparatus Conversion Table  
(Tamper Reading to Grams per Cubic Centimeter for Impact Test Core Weights)

Tamper Reading	Weight of Test Core (g)										
	2200	2250	2300	2350	2400	2450	2500	2550	2600	2650	2700
10	2.09	2.13	2.18	2.23	2.27	2.32	2.37	2.42	2.46	2.51	2.56
10.1	2.06	2.11	2.16	2.21	2.25	2.30	2.35	2.39	2.44	2.49	2.53
10.2	2.04	2.09	2.14	2.18	2.23	2.28	2.32	2.37	2.42	2.46	2.51
10.3	2.02	2.07	2.12	2.16	2.21	2.25	2.30	2.35	2.39	2.44	2.48
10.4	2.01	2.05	2.10	2.14	2.19	2.23	2.28	2.32	2.37	2.42	2.46
10.5	1.99	2.03	2.08	2.12	2.17	2.21	2.26	2.30	2.35	2.39	2.44
10.6	1.97	2.01	2.06	2.10	2.15	2.19	2.24	2.28	2.33	2.37	2.41
10.7	1.95	1.99	2.04	2.08	2.13	2.17	2.21	2.26	2.30	2.35	2.39
10.8	1.93	1.97	2.02	2.06	2.11	2.15	2.19	2.24	2.28	2.33	2.37
10.9	1.91	1.96	2.00	2.04	2.09	2.13	2.17	2.22	2.26	2.30	2.35
11	1.90	1.94	1.98	2.03	2.07	2.11	2.15	2.20	2.24	2.28	2.33
11.1	1.88	1.92	1.96	2.01	2.05	2.09	2.13	2.18	2.22	2.26	2.31
11.2	1.86	1.90	1.95	1.99	2.03	2.07	2.12	2.16	2.20	2.24	2.29
11.3	1.85	1.89	1.93	1.97	2.01	2.06	2.10	2.14	2.18	2.22	2.26
11.4	1.83	1.87	1.91	1.95	2.00	2.04	2.08	2.12	2.16	2.20	2.25
11.5	1.81	1.85	1.90	1.94	1.98	2.02	2.06	2.10	2.14	2.18	2.23
11.6	1.80	1.84	1.88	1.92	1.96	2.00	2.04	2.08	2.12	2.17	2.21
11.7	1.78	1.82	1.86	1.90	1.94	1.98	2.03	2.07	2.11	2.15	2.19
11.8	1.77	1.81	1.85	1.89	1.93	1.97	2.01	2.05	2.09	2.13	2.17
11.9	1.75	1.79	1.83	1.87	1.91	1.95	1.99	2.03	2.07	2.11	2.15
12	1.74	1.78	1.82	1.86	1.90	1.94	1.97	2.01	2.05	2.09	2.13

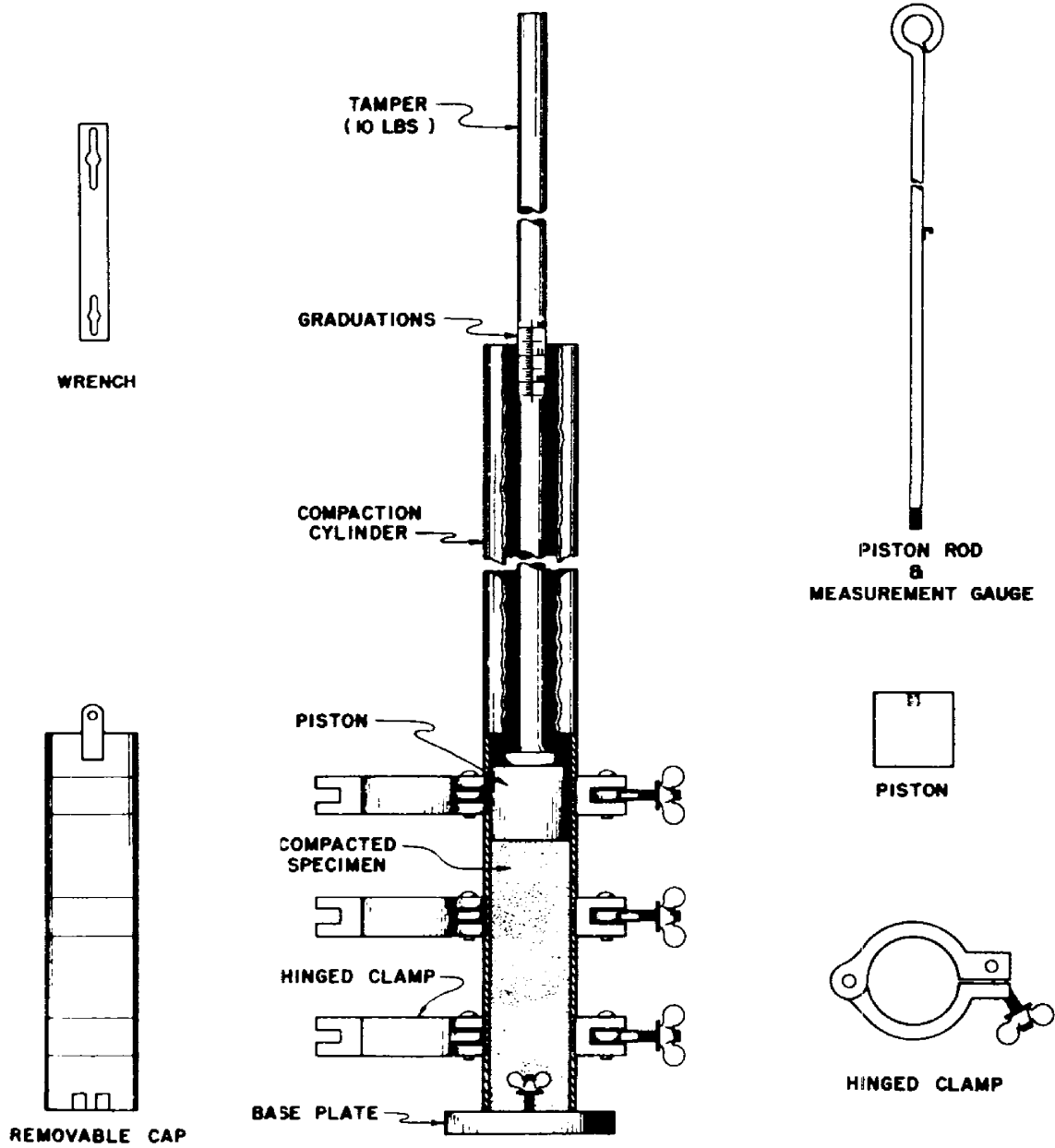

Fabrication Drawings available at:

Transportation Laboratory  
5900 Folsom Blvd  
Sacramento, CA 95819

FIGURE 1. California Impact Compaction Apparatus



STATE OF CALIFORNIA DEPARTMENT OF TRANSPORTATION  
RELATIVE COMPACTION TEST  
TL-297 (REV 10/2005)

Job Stamp		Location			Test No.																			
		Material			From																			
		Impact by			Sand Vol. By																			
		Date			Date																			
<b>SAND VOLUME DATA</b>		Remarks:																						
A	Initial Wt. of Sand (g)																							
B	Wt. of Residue (g)																							
C	Wt. of Sand Used (A-B)																							
D	Cone Correction (g)		<b>IMPACT TEST DATA</b>																					
E	Wt. of Sand in Hole (C-D)		I	Initial Wet Weight of Test Specimen (g)																				
F	Sand Density (g/cc)			Increment	1	2	3	4																
G	Volume of Hole (E/F)			Water Adjustment (g)																				
H	Wet Density (g/cc) (L/G)		J	Tamper Reading																				
			K	Adjusted Wet Density (g/cc)																				
<b>ROCK CORRECTION</b>			<div style="display: flex; align-items: center; justify-content: center;"> <div style="writing-mode: vertical-rl; transform: rotate(180deg); font-size: small; margin-right: 5px;">Adjusted Wet Density (g/cc)</div>  </div>																					
L	Total Sample Weight (g)																							
M	+ 3/4-inch Weight in Air (g)																							
N	+3/4-inch Weight in Water (g)																							
O	+3/4-inch Volume (M - N)																							
P	% +3/4-inch 100 * (M / L)																							
Q	% -3/4-inch 100 - P																							
R	Density of +3/4-inch (M / O)																							
S	(%+3/4-inch) / Density of +3/4-inch (P / RY)																							
T	(%-3/4-inch) / Density of -3/4-inch (Q / K)																							
U	Sum of S and T (S + T)																							
V	Average Adjusted Wet Density (100 / U)																							
Percent Relative Compaction*		Spec							Failed or less															
									Passed															
			* (H / K) for 10% or less +3/4-inch; (H / V) for > 10% +3/4-inch																					
<b>MOISTURE ADJUSTMENT FOR AGGREGATE BASE PAY QUANTITY</b>					<b>+ 3/4-inch Aggregate Adjustment (Y)</b>																			
a	In-place Wet wt.		e	Test Spec. Wet Wt. (opt.)																				
b	In-place Dry wt.		f	Test Spec. Dry Wt.																				
c	In-place Water ( a - b)		g	Test Spec. Water (e - f)																				
d	In-place % Water ( c / b)		h	Test Spec. % Water (g / f)																				
Moisture Corr. (h + 1%) - d =					<table style="width:100%; border-collapse: collapse;"> <tr> <td style="width:15%; text-align: left;"><u>% + 3/4-inch (P)</u></td> <td style="width:15%; text-align: left;"><u>Adjustment</u></td> </tr> <tr> <td>20 or less.....</td> <td>1.00</td> </tr> <tr> <td>21-25.....</td> <td>0.99</td> </tr> <tr> <td>26-30.....</td> <td>0.98</td> </tr> <tr> <td>31-35.....</td> <td>0.97</td> </tr> <tr> <td>36-40.....</td> <td>0.96</td> </tr> <tr> <td>41-45.....</td> <td>0.95</td> </tr> <tr> <td>46-50.....</td> <td>0.94</td> </tr> </table>				<u>% + 3/4-inch (P)</u>	<u>Adjustment</u>	20 or less.....	1.00	21-25.....	0.99	26-30.....	0.98	31-35.....	0.97	36-40.....	0.96	41-45.....	0.95	46-50.....	0.94
<u>% + 3/4-inch (P)</u>	<u>Adjustment</u>																							
20 or less.....	1.00																							
21-25.....	0.99																							
26-30.....	0.98																							
31-35.....	0.97																							
36-40.....	0.96																							
41-45.....	0.95																							
46-50.....	0.94																							
Moisture Corr. in excess of Opt. + 1%			% Moisture by CTM 226																					

FIGURE 2. California Relative Compaction Test Worksheet

STATE OF CALIFORNIA DEPARTMENT OF TRANSPORTATION  
RELATIVE COMPACTION TEST  
TL-297 (REV 10/2005)

# EXAMPLE

Job Stamp		Location		Test No.																				
		Material		From																				
		Impact by		Sand Vol. By																				
		Date		Date																				
<b>SAND VOLUME DATA</b>			<b>EXAMPLE</b>																					
A	Initial Wt. of Sand (g)	11250						Remarks:																
B	Wt. of Residue (g)	1429																						
C	Wt. of Sand Used (A-B)	9821																						
D	Cone Correction (g)	1641																						
			<b>IMPACT TEST DATA</b>																					
E	Wt. of Sand in Hole (C-D)	8180	I	Initial Wet Weight of Test Specimen (g)	2500																			
F	Sand Density (g/cc)	1.55		Increment	1	2	3	4																
G	Volume of Hole (cc) (E/F)	5277		Water Adjustment (g)	-50	0	50																	
H	Wet Density (g/cc) (L/G)	2.06	J	Tamper Reading	11.4	11.0	11.2																	
			K	Adjusted Wet Density (g/cc)	2.08	2.15	2.12																	
<b>ROCK CORRECTION</b>				Adjusted Density																				
L	Total Sample Weight (g)	10865																						
M	+3/4-inch Weight in Air (g)	3568																						
N	+3/4-inch Weight in Water (g)	2322																						
O	+3/4-inch Volume (M - N)	1246																						
P	% +3/4-inch $100 * (M / L)$	32.8																						
Q	% -3/4-inch $100 - P$	67.2																						
R	Density of +3/4-inch (M / O)	2.86																						
S	(%+3/4-inch) / Density of +3/4-inch (P / R <sub>Y</sub> )	11.8																						
T	(%-3/4-inch) / Density of -3/4-inch (Q / K)	31.3																						
U	Sum of S and T (S + T)	43.1																						
V	Average Adjusted Wet Density (100 / U)	2.32																						
Percent Relative Compaction*		Spec	Failed						89 or less															
		90	Passed																					
*(H / K) for 10% or less +3/4-inch; (H / V) for > 10% +3/4-inch																								
<b>MOISTURE ADJUSTMENT FOR AGGREGATE BASE PAY QUANTITY</b>					<b>+ 3/4-inch Aggregate Adjustment (Y)</b>																			
a	In-place Wet wt.		e	Test Spec. Wet Wt. (opt.)	<table style="width:100%; border-collapse: collapse;"> <thead> <tr> <th style="text-align:left;">% + 3/4-inch (P)</th> <th style="text-align:left;">Adjustment</th> </tr> </thead> <tbody> <tr><td>20 or less.....</td><td>1.00</td></tr> <tr><td>21-25.....</td><td>0.99</td></tr> <tr><td>26-30.....</td><td>0.98</td></tr> <tr><td>31-35.....</td><td>0.97</td></tr> <tr><td>36-40.....</td><td>0.96</td></tr> <tr><td>41-45.....</td><td>0.95</td></tr> <tr><td>46-50.....</td><td>0.94</td></tr> </tbody> </table>				% + 3/4-inch (P)	Adjustment	20 or less.....	1.00	21-25.....	0.99	26-30.....	0.98	31-35.....	0.97	36-40.....	0.96	41-45.....	0.95	46-50.....	0.94
% + 3/4-inch (P)	Adjustment																							
20 or less.....	1.00																							
21-25.....	0.99																							
26-30.....	0.98																							
31-35.....	0.97																							
36-40.....	0.96																							
41-45.....	0.95																							
46-50.....	0.94																							
b	In-place Dry wt.		f	Test Spec. Dry Wt.																				
c	In-place Water ( a - b )		g	Test Spec. Water (e - f)																				
d	In-place % Water ( c / b )		h	Test Spec. % Water (g / f)																				
Moisture Corr. (h + 1%) - d =																								
Moisture Corr. in excess of Opt. + 1%		% Moisture by CTM 226																						

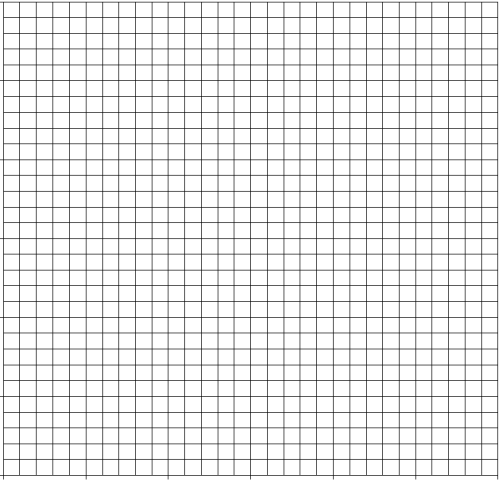
# EXAMPLE

FIGURE 3. Example of California Relative Compaction Test Worksheet